

# 杭州永创智能设备股份有限公司

Hangzhou Youngsun Intelligent Equipment Co., Ltd.

地址: 中国浙江杭州西湖科技园区西园七路2号 310030  
ADD: No.2, Xiyuan 7RD, West lake Science & Technology  
Development Area, Hangzhou, China 310030  
TEL: 0571-85120100 85120101 85120102  
TEL(oversea): +86-571-87978016 85120117

http://www.youngsunpack.com  
E-mail: sale@youngsunpack.com  
info@youngsunpack.com (外贸oversea)

北京办事处 010-63728237  
北京市大兴区黄村镇保利茉莉公馆23-505

长春办事处 0431-89347696  
吉林省长春市绿园区南阳路新奥蓝城2-404

长沙办事处 0371-86969218  
湖南省长沙市长沙县德普企业公园东区17-1栋

成都办事处 028-87644699  
四川省成都市锦江区下东大街芷泉段68号时代8号大厦2-1-802

重庆办事处 023-68420765  
重庆市九龙坡区科园一街新锐地带A栋13-6

佛山办事处 0757-81688946  
广东省佛山市南海区桂澜北路28号万达广场E座1306号

贵阳办事处 0851-85878217  
贵州省贵阳市观山湖区茅台国际商务中心B座2305室

合肥办事处 0551-63652665  
安徽省合肥市经开区汤口路2766号香馨创客产业园13幢厂房

昆明办事处 0871-63570377  
云南省昆明市官渡区鑫都韵城1-2-2402

南昌办事处 0791-88558331  
江西省南昌市红谷滩区绿地中央广场A1写字楼1101室

南京办事处 025-87199409  
江苏省南京市江宁区淳化街道科建路29号有志大厦B2座420室

南宁办事处 0771-3350618  
广西壮族自治区南宁市青秀区中柬路8号龙光世纪A座801室

青岛办事处 0532-87632250  
山东省青岛市李沧区万年泉路61号瑞康花园7-1-202

上海办事处 021-64138355  
上海市青浦区松复路1888号

苏州办事处 0512-67225343  
江苏省苏州市虎丘区横塘街道宝带西路1099号汇金科创中心2-403A

武汉办事处 027-84617921  
湖北省武汉市沌口经济技术开发区东合中心E座703室

西安办事处 029-86636826  
陕西省西安市未央区四海中心A座1010室

厦门办事处 0592-5067583  
福建省厦门市同安区湖里园美溪道35号

郑州办事处 0371-86027050  
河南省郑州市郑东新区创业路九号绿地双子塔北塔614室



无人包装 智能系统



20240105 A版



# YOUNGSUN®

股票代码(Stock code): 603901

## Unmanned Packing, Intelligent System

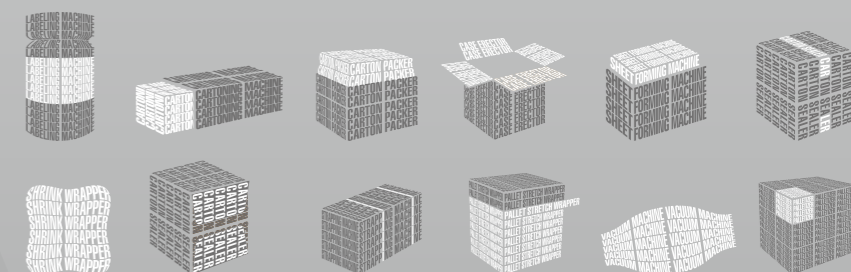

# DEVELOPMENT HISTORY

## 发展历程

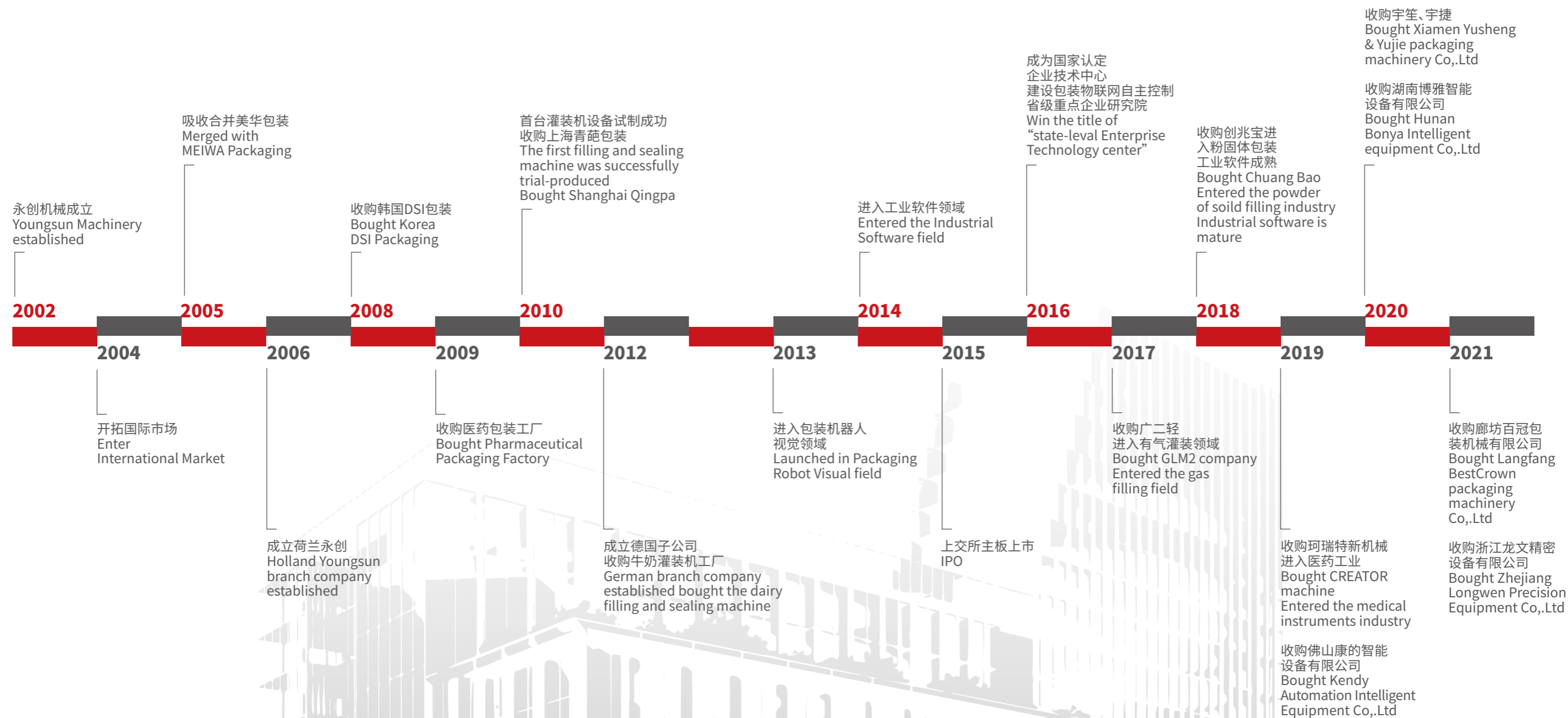

## YOUNGSUN HONORS 永创荣誉

- ☑ 国家高新技术企业  
National High-tech Enterprises
- ☑ 中国标准创新贡献奖  
China Standard Innovation Contribution Award
- ☑ 中国驰名商标  
Famous Trademark of China
- ☑ 国家认定企业技术中心  
National Certified Enterprise Technology Center
- ☑ 国家知识产权示范企业  
National Intellectual Property Demonstration Enterprises
- ☑ 杭州市政府质量奖  
Hangzhou Government Quality Award

是浙江省级博士后站建设单位, 浙江省级工业设计中心, 浙江省AAA级守合同重信用单位。

是全国包装机械标准化技术委员会成型装填封口集合机械分技术委员会秘书处单位, 浙江省智能制造标准联盟人工智能标准化组副组长单位。

是工信部智能制造综合标准化与新模式应用项目联合承担单位, 浙江省重大科技专项承担单位, 浙江省人工智能标准化战略重大试点项目承担单位。

拥有授权专利、软著565项, 其中发明专利71项(含PCT25项), 境内、境外注册商标60余项。

A post-doctoral station construction unit at Zhejiang level, an industrial design center at Zhejiang level, and a contract-abiding and credit-abiding unit at AAA level in Zhejiang Province.

The Secretariat unit of National Packaging Machinery Standardization Technical Committee, the sub-committee of Forming, Filling and Sealing Machinery, and the vice-chairman of AI Standardization Group of Zhejiang Intelligent Manufacturing Standards Alliance.

The joint undertaking unit of the Intelligent Manufacturing Integrated Standardization and New Model Application Project of the Ministry of Industry and Information Technology, the major scientific and technological undertaking unit of Zhejiang Province, and the major pilot project undertaking unit of the strategy of artificial intelligence standardization in Zhejiang Province.

There are 565 authorized patents and soft books, including 71 invention patents (including PCT 25) and more than 60 domestic and overseas registered trademarks.

## COOPERATIVE PARTNERS 合作伙伴



\* 企业排名不分先后  
Companies are ranked in no particular order



# INTELLIGENT SYSTEM 智能系统

- ① 烘焙类枕包盒装食品包装生产线  
Pillow and box packaging line for baking products
- ② 颗粒类袋装食品包装生产线  
Bag packaging line for granule products
- ③ 灌装液体类瓶装食品包装生产线  
Bottle filling and packaging line for liquid products
- ④ 定量粉末类条状食品包装生产线  
Quantitative strip packaging line for powder products
- ⑤ 粉, 固类罐装食品包装生产线  
Tin packaging line for powder and solid products
- ⑥ 气调保鲜类食品包装生产线  
Modified atmosphere packaging line for foods industry

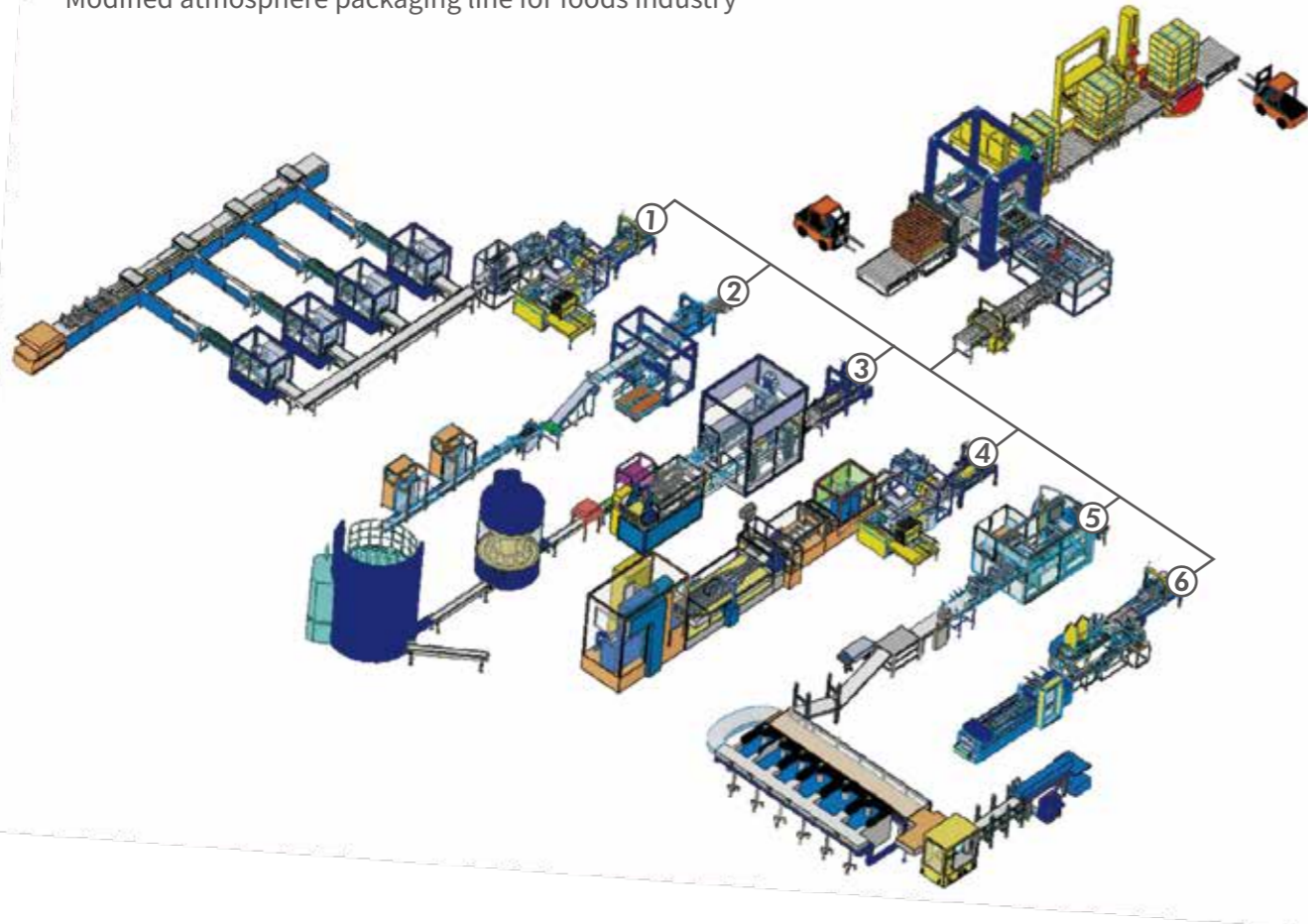

机器与自动流水线相连后其效果更为显著, 这就是永创特有的——无人包装 智能系统!  
After the machine is connected with the automatic conveyor line, the effect is more remarkable.  
This is the unique of YOUNGSUN - the intelligent system of unmanned packaging.

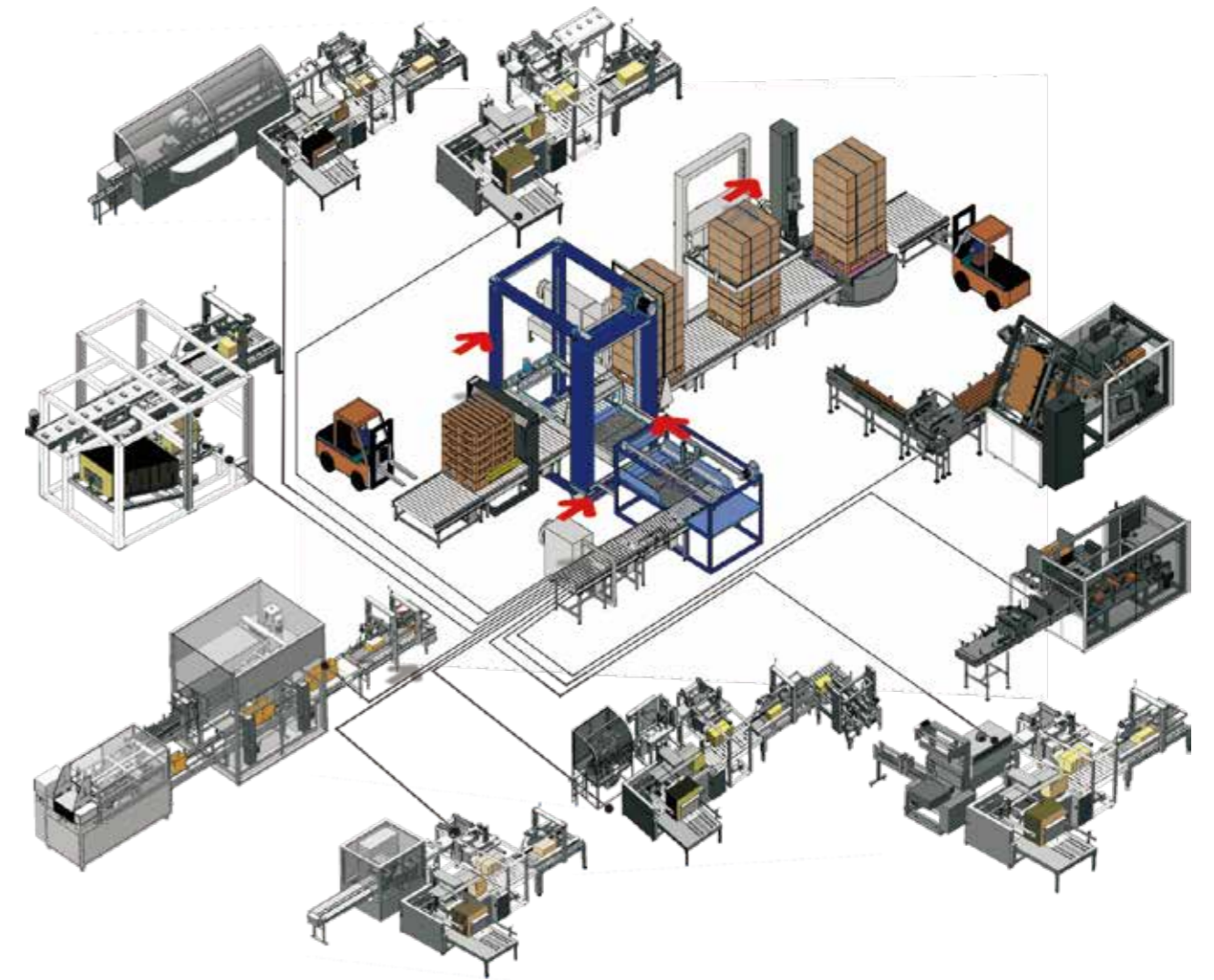

根据您的特殊需求, 设计最具效率的无人化包装系统, 是永创的专长!  
According to your special requirement, designing the most efficient unmanned packaging system is our specialty.

# PRODUCTS CATALOGUE

## 产品系列目录

### 一次包装

乳品饮料灌装封口机 Dairy beverage filling & Sealing machine	01-09
啤酒饮料灌装封口机 Beer beverage filling & Capping machine	10-14
全自动立式包装机 Vertical packaging machine	15-27
真空包装机及气调保鲜包装机 Vacuum & Modified atmosphere packaging machine	28-31
枕式包装机 Horizontal packaging machine	32-36
泡罩机 Blister packaging machine	37-40
装盒机 Cartonning machine	41-44

### 二次包装

膜包套袋热缩机 Shrink wrapping machine	45-54
纸包机 Wrapper around case packer	55-57
纸箱成型机 Carton erector	58-61
装箱机 Carton packer	62-65
贴标机 Labeling machine	66-70
封箱机 Carton sealer	71-80
打包机 Strapping machine	81-94
缠绕机 Pallet wrapper	95-102
机器人和蜘蛛手 Robot & Delta robot	103-108
码卸垛机 Palletizer & Depalletizer machine	109-114

# DAIRY BEVERAGE FILLING & SEALING MACHINE

## 乳品、饮料灌装封口机

全自动直线式纸(塑)杯灌装封口机  
Automatic linear paper (plastic) cup filling & sealing machine



YSZB-20000H(超洁净型)  
Ultra Clean Type



YSZB-5000



YSZB-8000(10000/20000)

型号 Model	产量 (杯/小时) Output (cph)	步进杯数 Step cups	灌装量 (g/ml) Filling volume	耗气量 (m <sup>3</sup> /min) Air consumption	重量 (t) Weight	功率 (kW) Power
YSZB-5000	5000	4	50-300	0.8	3.2	9.5
YSZB-8000	8000	6	50-300	0.8	4.2	10.5
YSZB-10000	10000	8	50-300	0.9	4.8	11.5
YSZB-20000	20000	16	50-300	1.2	12	45(超洁净型约55) Ultra clean type (55)

全自动塑杯成型灌装封口机 / 全自动塑杯成型膜内贴灌装封口机  
 Automatic plastic cup forming filling & sealing machine  
 Automatic plastic cup forming filling & sealing machine with in mold labeling function



YSDXR-20000HB  
 YSDXR-12000 IML

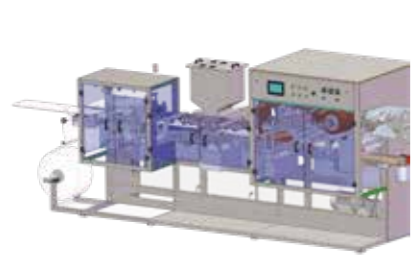

YSDXR-6000GS (10000GS)

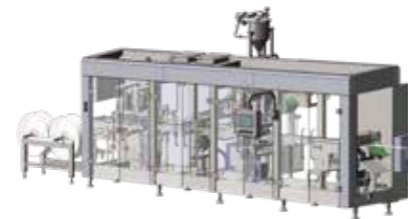

YSDXR-8000 (12000)



YSSH-1400 塑盒封口机 Plastic box sealer

型号 Model	产量 (杯/小时) Output (cup/h)	功率 (kW) Power	步进杯数 Step cups	灌装量 (g/ml) Filling volume	耗气量 (m <sup>3</sup> /min) Air consumption	重量 (t) Weight
YSDXR-12000	12000-20000	65	12	30-150	1.8	4.5
YSDXR-20000HB	20000	85	12	30-150	2.0	7.5
YSDXR-40000HB	36000	101	24	30-150	2.5	8.2
YSDXR-6000IML	6000	115	8	100-250	1.5	7.6
YSDXR-12000IML	12000	130	12	100-250	1.8	8.5

全自动旋转式纸(塑)杯灌装封口机  
 Automatic rotary paper (plastic) cup filling & sealing machine



型号 Model	产量 (杯/小时) Output (cph)	功率 (kW) Power	灌装头数量 Filling heads	灌装量 (g/ml) Filling volume	耗气量 (m <sup>3</sup> /min) Air consumption	重量 (t) Weight
YSXZB-2500	2500	3.5	2	90-400	0.8	2.5
YSXZB-3500	3500	3.5	3	90-400	0.8	3
YSXZB-5000	5000	4.5	4	90-400	0.8	4

超洁净直线型塑瓶灌装机  
Ultra clean linear plastic bottle filler



全自动旋转式塑瓶灌装封口机  
Automatic rotary filling & sealing machine for plastic bottles



型号 Model	产量 (瓶/小时) Output (bph)	灌装头数量 Filling heads	灌装量 (g/ml) Filling volume	灌装温度 (°C) Filling temp	塑瓶材质 Material
YSCSP-10000	14000	8-16	100-1500	6-90	PET/PP/PE

型号 Model	产量 (瓶/小时) Output (bph)	功率 (kW) Power	灌装头数量 Filling heads	灌装量 (g/ml) Filling volume	瓶径/瓶高 (mm) Dia./height	重量 (t) Weight
YGF24-20000	20000	14.2	24	100-1000	Φ40-85/80-280	4
YGF32-25000	25000	14.2	32	100-1000	Φ40-85/80-280	5
YGF40-30000	30000	18.17	40	100-1000	Φ40-85/80-280	6
YGF48-36000	36000	19	48	100-1000	Φ40-85/80-280	7

全自动直线式塑瓶灌装封口机  
Automatic linear plastic bottle filling & sealing machine



全自动旋转式玻璃瓶灌装旋盖机  
Automatic rotary filling & capping machine for glass bottles



型号 Model	产量 (瓶/小时) Output (bph)	功率 (kW) Power	灌装头数量 Filling heads	灌装量 (g/ml) Filling volume	耗气量 (m <sup>3</sup> /min) Air consumption	重量 (t) Weight
YSSP-2000	2000	11	6	500-1250	0.7	3.5
YSSP-6000	6000	26	12	100-500	0.8	4.5

产量 (瓶/小时) Output (bph)	功率 (kW) Power	洗瓶夹数量 Number of bottle washers	灌装头数量 Filling heads	旋盖头数量 Number of caps	瓶径/瓶高 (mm) Dia./height	重量 (t) Weight
36000	12	72	60	18	Φ40-85/150-300	20

喷淋式隧道杀菌机  
Spray tunnel sterilizer

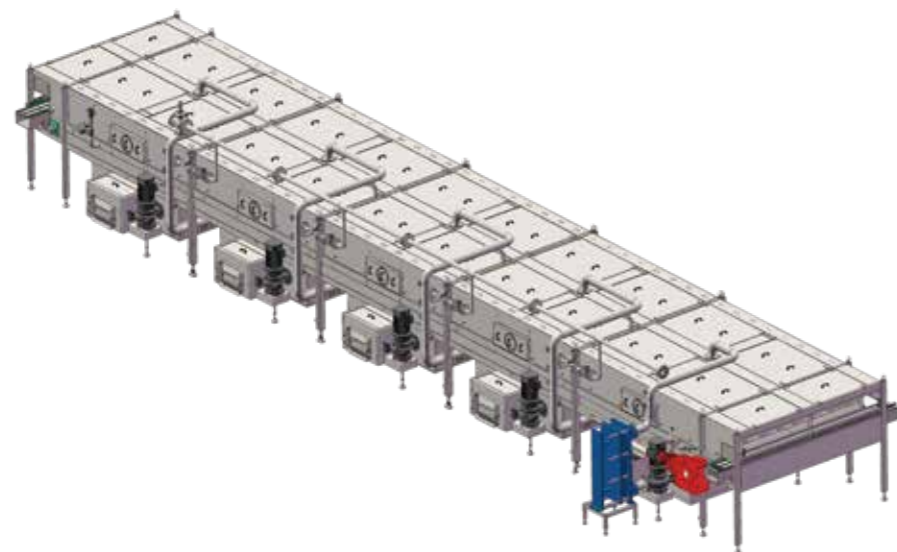

## BEER FILLING & CAPPING MACHINE 啤酒灌装封口机

型号 Model	系统区域数量 Number of system areas	杀菌机功率 (kW) Sterilizer power	冷却机功率 (kW) Cooler power	水压力 (MPa) Water pressure	蒸汽压力 (MPa) Steam pressure
YSJ-4	4	13.87	-	0.2	0.4-0.7
YSJ-5	5	16.87	5.87	0.2	0.5-0.8
YSJ-6	6	19.87	5.87	0.2	0.5-0.8
YSJ-7	7	22.87	5.87	0.2	0.5-0.8
YSJ-8	8	25.87	5.87	0.2	0.5-0.8



直立袋灌装旋盖机  
Pouch bag filling & capping machine



洗瓶机 YSXP30 (40)  
Bottle washer

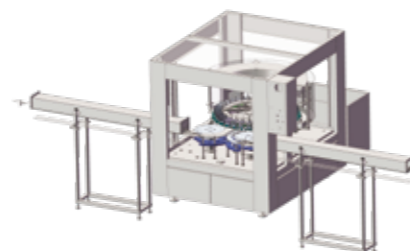

理瓶机 YLP01  
Bottle unscrambler



PGF系列易拉罐灌装机  
PGF series can filler & sealer



YSTGF系列易拉罐灌装机  
YSTGF series can filler & sealer



型号 Model	产能 (cph/ml) Capacity	阀头数 Valves	温度(°C) Temp.	罐体直径/高度 (mm) Din/Height	外形尺寸L*W*H (mm) Overall dimension	重量 (t) Weight	功率 (kW) Power
PGF40	24000/330 18000/500	40	0-4	Φ50-60/85-195	12000*6000*2500	10	19.62
PGF50	36000/330	50	0-4	Φ50-90/85-195	12000*6000*2500	12	19.62
PGF108	60000/500 60000/330	108	≤4	Φ50.8-76/90-200	12500*6500*2500	23	19.62
YDL124	72000/500	124	0-4	Φ50-76/85-200	6000*5500*3500	25	19.62
YDL144	90000/330	144	0-4	Φ50-76/85-200	6000*5500*3500	25	19.62

型号 Model	产能 (cph/ml) Capacity	阀头数 Valves	灌装温度 (°C) Filling temp	罐体直径/高度 (mm) Din/Height	接缝封头 Seaming head	外形尺寸L*W*H (mm) Overall dimension	功率 (kW) Power
YSTGF9/2	6000/330	9	0-4	Φ50-66/70-175	2	3153*1980*2350	3.0
YSTGF20/4	12000/330	20	0-4	Φ50-66/70-175	4	3153*1980*2350	3.0
YSTGF30/6	18000/330	30	0-4	Φ50-66/70-175	6	4823*2607*2170	4.5

JZY系列玻璃瓶灌装机  
JZY series glass filler & crowner



SXP系列双端洗瓶机  
SXP series double-end bottle washer



PIISC系列节能型杀菌机  
PIISC series energy-efficient pasteurizer



型号 Model	产能 (bph) Capacity	阀头数 Valves	灌装温度 (°C) Filling temp	适应直径/高度 (mm) Dia./Height	压盖头数 Capper heads	外形尺寸L*W*H (mm) Overall dimension
JZY84/14	24000	84	≤4	52-82	14	7800*4200*3500
JZY96/14	30000	96	≤4	52-82	14	7800*4200*3500
JZY108/18	36000	108	≤4	52-82	18	8100*4600*3500
JZY120/18	40000	120	≤4	52-82	18	8100*5000*3500
JZY132/18	40000	132	≤10	52-82	18	9000*5000*3500
JZY144/24	50000	144	≤4	52-82	24	9500*5000*3500

型号 Model	产量 (瓶/小时) Output (bph)	瓶径/瓶高 (mm) Dia./height	外形尺寸L*W*H (mm) Overall dimension
SXP32D	24000	Φ60-82/160-295	17.3*7.4*4.6
SXP32H	24000	Φ60-83/160-295	19.46*7.2*4.5
SXP44D	36000	Φ60-83/160-295	17.4*8.4*4.5
SXP44J	40000	Φ60-83/160-295	20.6*8.4*4.5
SXP44JH	40000-50000	Φ60-83/160-295	22*8.4*4.5
SXP47	50000	Φ60-83/160-295	22.4*9.2*4.5

# VERTICAL PACKAGING MACHINE

## 全自动立式包装机

组合秤包装一体机  
Combination MHW & packaging machine

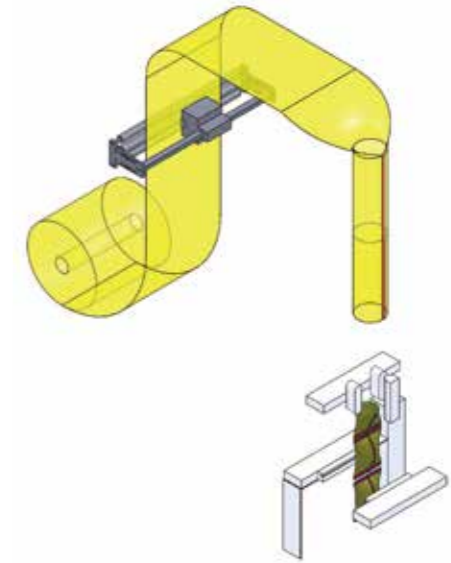

型号 Model	YS-BS-2010Y1005-IP-P	YS-BS-2010Y1016-IP-P	YS-BS-2010Y1405-IP-P	YS-BS-2010Y1416-IP-P
袋型 Bag type	枕式袋 Pillow bag	枕式袋 Pillow bag	枕式袋 Pillow bag	枕式袋 Pillow bag
包装速度 (P/M) Speed	10-60	10-60	10-70	10-70
枕式袋 (mm) Pillow bag	袋宽W 60-200 袋长L 60-260	袋宽W 60-200 袋长L 60-260	袋宽W 60-200 袋长L 60-260	袋宽W 60-200 袋长L 60-260
薄膜材料 packaging material	OPP/AL/PE, PET/VMPET etc.	OPP/AL/PE, PET/VMPET etc.	OPP/AL/PE, PET/VMPET etc.	OPP/AL/PE, PET/VMPET etc.
膜宽 (mm) Film width	420	420	420	420
整机尺寸 (mm) Outer dimensions	1650*1090*2170	1650*1090*2170	1650*1090*2170	1650*1090*2170
电压 Power supply	AC220V 50Hz	AC220V 50Hz	AC220V 50Hz	AC220V 50Hz
总功率 (kW) Total power	5.0	5.5	6.0	6.5

背封间歇式立式机 (中小袋型/中大袋型)  
Back sealed, intermittent machine (Small bag/Large bag)

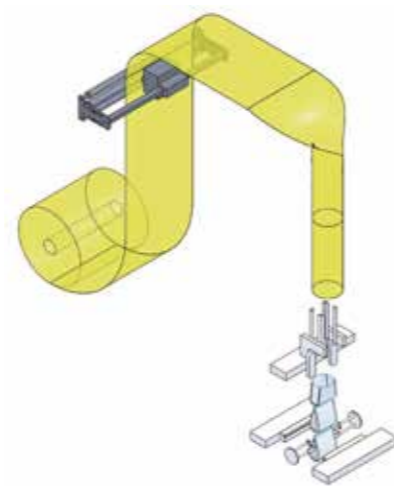

型号 Model	YS-BS-2520-IP-A (Small)
袋型 Bag type	枕式袋、叉角袋 Pillow bag & Gusseted bag
包装速度 (包/分钟) Speed (bag/min)	10-90
枕式袋 (mm) Pillow bag	袋宽W 60-250, 袋长L 60-400
叉角袋 (mm)(正宽>侧宽) Gusseted bag	正宽W 50-220, 侧宽D 35-110, 袋长L 60-400
薄膜材料 packaging material	OPP/AL/PE, PET/VMPET etc.
膜宽 (mm) Film width	520
整机尺寸 (mm) Outer dimensions	1800*1270*1615
电压 Power supply	3N-PN-50Hz 380V (3相5线)3P 5 wires
总功率 (kW) Total power	5.0

型号 Model	YS-BS-2520-IP-P (Small)
袋型 Bag type	枕式袋 Pillow bag
包装速度 (包/分钟) Speed (bag/min)	10-100
枕式袋 (mm) Pillow bag	袋宽W 60-250, 袋长L 60-400
叉角袋 (mm)(正宽>侧宽) Gusseted bag	-
薄膜材料 packaging material	OPP/AL/PE, PET/VMPET etc.
膜宽 (mm) Film width	520
整机尺寸 (mm) Outer dimensions	1800*1270*1615
电压 Power supply	3N-PN-50Hz 380V (3相5线)3P 5 wires
总功率 (kW) Total power	5.0

背封间歇式立式机 (中小袋型/中大袋型)  
Back sealed, intermittent machine (Small bag/Large bag)



型号 Model	YS-BS-3620-IP-A (Large)
袋型 Bag type	枕式袋、叉角袋 Pillow bag & Gusseted bag
包装速度 (包/分钟) Speed (bag/min)	10-80
枕式袋 (mm) Pillow bag	袋宽W 60-360, 袋长L 60-500
叉角袋 (mm)(正宽>侧宽) Gusseted bag	正宽W 50-330, 侧宽D 45-140, 袋长L 60-500
薄膜材料 packaging material	OPP/AL/PE, PET/VMPET etc.
膜宽 (mm) Film width	730
整机尺寸 (mm) Outer dimensions	2220*1555*1855
电压 Power supply	3N-PN-50Hz 380V (3相5线)3P 5 wires
总功率 (kW) Total power	6.0

型号 Model	YS-BS-3620-IP-P (Large)
袋型 Bag type	枕式袋 Pillow bag
包装速度 (包/分钟) Speed (bag/min)	10-90
枕式袋 (mm) Pillow bag	袋宽W 60-360, 袋长L 60-500
叉角袋 (mm)(正宽>侧宽) Gusseted bag	-
薄膜材料 packaging material	OPP/AL/PE, PET/VMPET etc.
膜宽 (mm) Film width	730
整机尺寸 (mm) Outer dimensions	2220*1555*1855
电压 Power supply	3N-PN-50Hz 380V (3相5线)3P 5 wires
总功率 (kW) Total power	6.0

背封连续式立式机(中小袋型/中大袋型)  
Back sealed, continuous machine (Small bag/Large bag)

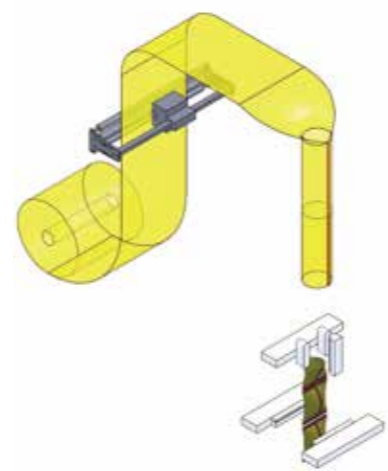

型号 Model	YS-BS-2520-CP-A (Small)
袋型 Bag type	枕式袋、叉角袋 Pillow bag & Gusseted bag
包装速度(包/分钟) Speed (bag/min)	10-130
枕式袋(mm) Pillow bag	袋宽W 60-250, 袋长L 60-400
叉角袋(mm)(正宽>侧宽) Gusseted bag	正宽W 50-220, 侧宽D 35-110, 袋长L 60-400
薄膜材料 packaging material	OPP/AL/PE, PET/VMPET etc.
膜宽(mm) Film width	520
整机尺寸(mm) Outer dimensions	1800*1200*1615
电压 Power supply	3N-PN-50Hz 380V (3相5线)3P 5 wires
总功率(kW) Total power	6.5

型号 Model	YS-BS-2520-CP-P (Small)
袋型 Bag type	枕式袋 Pillow bag
包装速度(包/分钟) Speed (bag/min)	10-110
枕式袋(mm) Pillow bag	袋宽W 60-360, 袋长L 60-400
叉角袋(mm)(正宽>侧宽) Gusseted bag	-
薄膜材料 packaging material	OPP/AL/PE, PET/VMPET etc.
膜宽(mm) Film width	520
整机尺寸(mm) Outer dimensions	1800*1200*1615
电压 Power supply	3N-PN-50Hz 380V (3相5线)3P 5 wires
总功率(kW) Total power	6.5

背封连续式立式机(中小袋型/中大袋型)  
Back sealed, continuous machine (Small bag/Large bag)



型号 Model	YS-BS-3620-CP-A (Large)	YS-BS-3620-CP-P (Large)
袋型 Bag type	枕式袋、叉角袋 Pillow bag & Gusseted bag	枕式袋 Pillow bag
包装速度(包/分钟) Speed (bag/min)	10-110	10-130
枕式袋(mm) Pillow bag	袋宽W 60-360, 袋长L 60-500	袋宽W 60-360, 袋长L 60-500
叉角袋(mm)(正宽>侧宽) Gusseted bag	正宽W 50-330, 侧宽D 45-140, 袋长L 60-500	-
薄膜材料 packaging material	OPP/AL/PE, PET/VMPET etc.	OPP/AL/PE, PET/VMPET etc.
膜宽(mm) Film width	730	730
整机尺寸(mm) Outer dimensions	2220*1555*1855	2220*1555*1855
电压 Power supply	3N-PN-50Hz 380V (3相5线)3P 5 wires	3N-PN-50Hz 380V (3相5线)3P 5 wires
总功率(kW) Total power	7.5	7.5

侧封烫边连续式立式机 (中小袋型/中大袋型)

Corner sealed, quare heated, continuous machine (Small bag/Large bag)

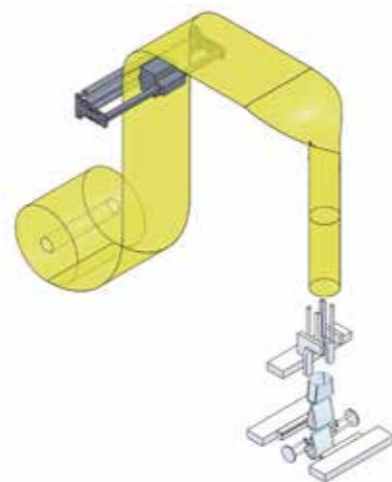

DOY拉链袋间歇式立式机 (中小袋型/中大袋型/大袋型)

DOY bag with ZIP, intermittent machine (Small bag/Large bag/Big bag)

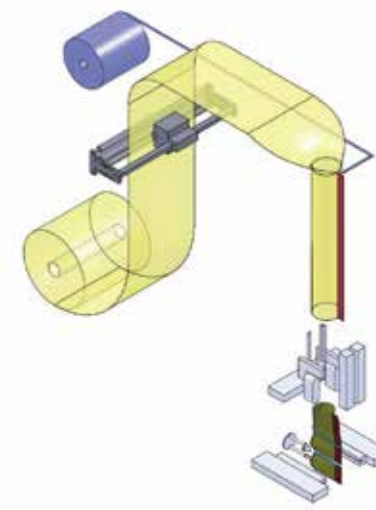

型号 Model	YS-CS-2520-CP-A (Small)	YS-CS-2520-CP-GB (Small)	YS-CS-3620-CP-A (Large)	YS-CS-3620-CP-GB (Large)
袋型 Bag type	枕式袋、烫边坐底袋 Pillow bag & 4 seal bag + bottom block	边封叉角坐底袋 Gusseted bag + bottom block	枕式袋 Pillow bag	边封叉角坐底袋 Gusseted bag + bottom block
包装速度 (包/分钟) Speed (bag/min)	10-120	10-120	10-110	10-110
枕式袋 (mm) Pillow bag	袋宽W 60-250 袋长L 60-400	袋宽W 60-250 袋长L 60-400	袋宽W 60-360 袋长L 60-500	袋宽W 60-360 袋长L 60-500
叉角袋 (mm) (正宽>侧宽) Gusseted bag	正宽W 50-220 侧宽D 35-110 袋长L 60-400	正宽W 50-220 侧宽D 35-110 袋长L 60-400	正宽W 50-330 侧宽D 45-140 袋长L 60-500	正宽W 50-330 侧宽D 45-140 袋长L 60-500
烫边袋 (mm) Corner seal bag	正宽W 65-170, 侧宽D 45-110 袋长L 60-400	-	正宽W 65-170, 侧宽D 45-140 袋长L 60-500	-
薄膜材料 packaging material	OPP/AL/PE, PET/VMPET etc.	OPP/AL/PE, PET/VMPET etc.	OPP/AL/PE, PET/VMPET etc.	OPP/AL/PE, PET/VMPET etc.
膜宽 (mm) Film width	520	520	730	730
整机尺寸 (mm) Outer dimensions	1800*1200*1615	1800*1200*1615	2220*1555*1855	2220*1555*1855
电压 Power supply	3N-PN-50Hz 380V (3相5线)3P 5 wires	3N-PN-50Hz 380V (3相5线)3P 5 wires	3N-PN-50Hz 380V (3相5线)3P 5 wires	3N-PN-50Hz 380V (3相5线)3P 5 wires
总功率 (kW) Total power	6.5	6.5	7.5	7.5

型号 Model	YS-D-2520-IP-ZIP	YS-D-3620-IP-ZIP	YS-CS-5020-IP-ZIP
袋型 Bag type	DOY拉链袋 DOY zipper bag	DOY拉链袋 DOY zipper bag	DOY拉链袋 DOY zipper bag
包装速度 (包/分钟) Speed (bag/min)	10-45	10-45	3-40
枕式袋 (mm) Pillow bag	底宽W 40-100 袋宽W 60-400 袋长L 60-200	底宽W 45-120 袋宽W 60-500 袋长L 60-310	底宽W 80-160 袋宽W 180-600 袋长L 250-485
薄膜材料 packaging material	OPP/AL/PE, PET/VMPET etc.	OPP/AL/PE, PET/VMPET etc.	OPP/AL/PE, PET/VMPET etc.
膜宽 (mm) Film width	520	730	1050
拉链材料 Zipper material	热封型拉链 Heat-sealed zipper	热封型拉链 Heat-sealed zipper	热封型拉链 Heat-sealed zipper
整机尺寸 (mm) Outer dimensions	1800*1200*1615	2220*1555*1855	2600*1900*2500
电压 Power supply	3N-PN-50Hz 380V (3相5线)3P 5 wires	3N-PN-50Hz 380V (3相5线)3P 5 wires	3N-PN-50Hz 380V (3相5线)3P 5 wires
总功率 (kW) Total power	6.0	7.0	8.0

防碎边、背封、间歇式倾斜机  
Back sealed, continuous/intermittent machine



(防碎边型 YS-BS-3620F-IP)

大袋型背封连续、间歇式立式机 (大袋型)  
Back sealed, continuous/intermittent machine (Big bag)

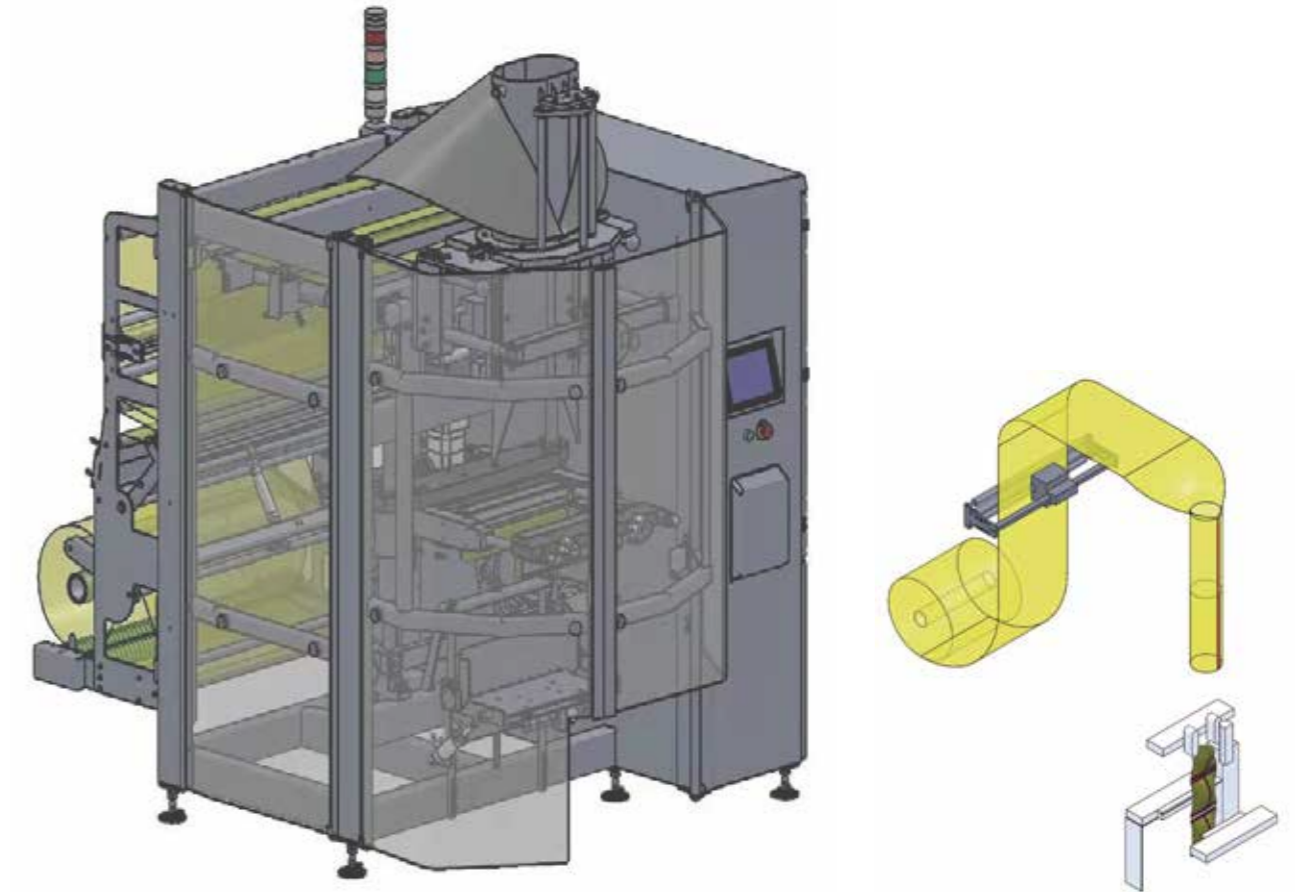

型号 Model	YS-BS-3620F-IP-A	YS-BS-3620F-IP-P
袋型 Bag type	枕式袋、叉角袋 Pillow bag & gusseted bag	枕式袋 Pillow bag
包装速度 (包/分钟) Speed (bag/min)	10-80	10-80
枕式袋 (mm) Pillow bag	袋宽W 60-360 袋长L 60-500	袋宽W 60-360 袋长L 60-500
叉角袋 (mm)(正宽>侧宽) Gusseted bag	正宽W 50-330, 侧宽D 45-140, 袋长L 60-500	-
薄膜材料 packaging material	OPP/AL/PE, PET/VMPET etc.	OPP/AL/PE, PET/VMPET etc.
膜宽 (mm) Film width	730	730
整机尺寸 (mm) Outer dimensions	2500*1555*1855	2500*1555*1855
电压 Power supply	3N-PN-50Hz 380V (3相5线)3P 5 wires	3N-PN-50Hz 380V (3相5线)3P 5 wires
总功率 (kW) Total power	6.5	6.5

型号 Model	YS-BS-5020-IP-A	YS-BS-5020-IP-P
袋型 Bag type	枕式袋、叉角袋 Pillow bag & gusseted bag	枕式袋 Pillow bag
包装速度 (包/分钟) Speed (bag/min)	3-45	3-45
枕式袋 (mm) Pillow bag	袋宽W 250-500 袋长L 200-850	袋宽W 250-500 袋长L 200-850
叉角袋 (mm) (正宽>侧宽) Gusseted bag	正宽W 100-430 侧宽D 50-200 袋长L 200-850	-
薄膜材料 packaging material	OPP/AL/PE, PET/VMPET etc.	OPP/AL/PE, PET/VMPET etc.
膜宽 (mm) Film width	1050	1050
整机尺寸 (mm) Outer dimensions	2500*1900*2500	2500*1900*2500
电压 Power supply	3N-PN-50Hz 380V (3相5线)3P 5 wires	3N-PN-50Hz 380V (3相5线)3P 5 wires
总功率 (kW) Total power	8.0	8.0

背封双列连续式立式机  
Back sealed, double lines continuous machine

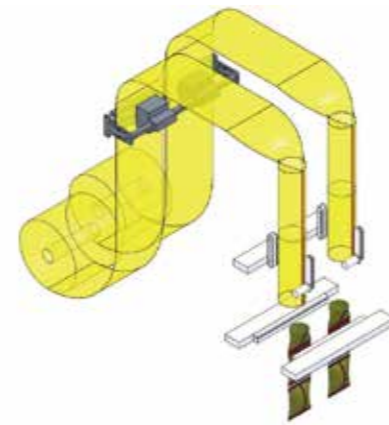

型号 Model	YS-BS-15T-IP-P
袋型 Bag type	双列枕式袋 Pillow bag, double lines
包装速度 (包/分钟) Speed (bag/min)	10-80 (单列 per line) 20-160 (双列 double lines)
枕式袋 (mm) Pillow bag	袋宽W 60-150 袋长L 60-250
薄膜材料 packaging material	OPP/AL/PE, PET/VMPET etc.
膜宽 (mm) Film width	≤320 (单列 per line)
整机尺寸 (mm) Outer dimensions	1900*1350*1550
电压 Power supply	3N-PN-50Hz 380V (3相5线)3P 5 wires
总功率 (kW) Total power	8.0

背封、三边封多列立式机  
Back sealed, triangle sealing multiple lane machine



型号 Model	YS-BS-523D-IP-P	YS-BS-648D-IP-P	YS-BS-670D-IP-P	YS-BS-6100D-IP-P
袋型 Bag type	多列枕式袋、三边封袋, 可选配横封挂孔(圆孔、蝴蝶孔)、斜封口、奶嘴封口等异型袋 Multiple pillow bag, triangle sealing bag, accept cross sealing hanging hole (circular hole, butterfly hole), helical sealing, pacifier sealing etc.			
列数 (最多) Lanes (max)	4	8	12	18
包装速度 (包/分钟) Speed (bag/min)	10-80	10-80	10-80	10-80
枕式袋 (mm) Pillow bag	袋宽W 22-50 袋长L 60-180	袋宽W 22-60 袋长L 60-180	袋宽W 22-60 袋长L 60-180	袋宽W 22-60 袋长L 60-180
薄膜材料 packaging material	OPP/AL/PE, PET/VMPET etc.	OPP/AL/PE, PET/VMPET etc.	OPP/AL/PE, PET/VMPET etc.	OPP/AL/PE, PET/VMPET etc.
膜宽 (mm) Film width	≤230	≤480	≤700	≤1000
整机尺寸 (mm) Outer dimensions	1500*950*1400	2100*1250*1860	2300*1300*2020	2300*1500*2020
电压 Power supply	3N-PN-50Hz 380V (3相5线)3P 5 wires	3N-PN-50Hz 380V (3相5线)3P 5 wires	3N-PN-50Hz 380V (3相5线)3P 5 wires	3N-PN-50Hz 380V (3相5线)3P 5 wires
总功率 (kW) Total power	4.0	5.0	6.5	8.0

水平给袋机 YS-YZD-280 (双工位)  
Horizontal machine (double-position)

包装速度 (包/分钟) Speed (bag/min)	70-90
电压及功率 Power supply	380V/50Hz 8kW
整机尺寸 (mm) Outer dimensions	3650*1950*2500
包装袋规格 (mm) Specification	L150-250; W80-110
气源压力(MPa) Air pressure	0.6-0.8



旋转给袋机 YS-YZD-X180  
Rotary machine

包装速度 (包/分钟) Speed (bag/min)	70-90
电压及功率 Power supply	380V/50Hz 8kW
整机尺寸 (mm) Outer dimensions	2130*1920*1600
包装袋规格 (mm) Specification	L150-250; W80-110
气源压力 (MPa) Air pressure	0.6-0.8



## VACUUM PACKAGING MACHINE 真空包装机 MODIFIED ATMOSPHERE PACKAGING MACHINE 气调保鲜包装机





YS-ZS-400S (420) 台式真空包装机  
Table type vacuum machine

抽真空能力 (m <sup>3</sup> /h) Pump capacity	20
工作循环 (times/min) Working cycle	1-5
外形尺寸 (mm) Dimensions	500*530*490
电源 Power	220V/50Hz 1.0kW (可选其它电压) (other voltage optional)
重量 (kg) Weight	68 (65)



YS-SQ-600SA (SA II /SP) 双室真空包装机  
Double-chamber vacuum machine

抽真空能力 (m <sup>3</sup> /h) Pump capacity	63
工作循环 (times/min) Working cycle	1-3
外形尺寸 (mm) Dimensions	1310*800*1150 1425*755*932
电源 Power	380V/50Hz 2.2kW (可选其它电压) (other voltage optional)
重量 (kg) Weight	240 (270/250)



YS-DQ-420 (400S/500/500S/600S) 单室真空包装机  
Vertical type vacuum machine

抽真空能力 (m <sup>3</sup> /h) Pump capacity	20
工作循环 (times/min) Working cycle	1-5
外形尺寸 (mm) Dimensions	500*530*1000 600*635*900 740*740*1050
电源 Power	220V/50Hz 1.0kW (可选其它电压) (other voltage optional)
重量 (kg) Weight	85 (88/125/120/130)



YS-ZKW-850 外抽式真空包装机  
Pumping vacuum machine

抽真空能力 (m <sup>3</sup> /h) Pump capacity	20
工作循环 (times/min) Working cycle	1-2
外形尺寸 (mm) Dimensions	1100*900*1700
电源 Power	220V/50Hz 2.25kW (可选其它电压) (other voltage optional)
重量 (kg) Weight	132



YS-DZ-420 立式真空包装机  
Vertical bag vacuum machine

抽真空能力 (m <sup>3</sup> /h) Pump capacity	20
工作循环 (times/min) Working cycle	1-5
外形尺寸 (mm) Dimensions	495*530*800
电源 Power	220V/50Hz 1.0kW (可选其它电压) (other voltage optional)
重量 (kg) Weight	80



YS-ZDZK-320Y / YS-ZDZK-420Y / YS-ZDZK-520Y  
连续式真空包装机 (硬膜)  
Continuous vacuum machine (hard film)

抽真空能力 (m <sup>3</sup> /h) Pump capacity	100/160/160-200
生产速度 (uph) Production speed	200-400
外形尺寸 (mm) Dimensions	4500*1030*1900 4900*1130*1900 5200*1230*1900
电源 Power	3P AC380V 50Hz 12/15/18kW
重量 (kg) Weight	1500/1800/2100



YS-SQ-550SP (550SA) 双室真空包装机  
Double-chamber vacuum machine

抽真空能力 (m <sup>3</sup> /h) Pump capacity	40
工作循环 (times/min) Working cycle	1-3
外形尺寸 (mm) Dimensions	1310*800*1150
电源 Power	380V/50Hz 2.0kW (可选其它电压) (other voltage optional)
重量 (kg) Weight	200



YS-ZDZK-320R / YS-ZDZK-420R / YS-ZDZK-520R  
连续式真空包装机 (软膜)  
Continuous vacuum machine (soft film)

抽真空能力 (m <sup>3</sup> /h) Pump capacity	100/160/160-200
生产速度 (uph) Production speed	200-400
外形尺寸 (mm) Dimensions	4500*1030*1900 4900*1130*1900 5200*1230*1900
电源 Power	3P AC380V 50Hz 12/15/18kW
重量 (kg) Weight	1500/1800/2100



YS-XCXZK-320 / YS-XCXZK-420 / YS-XCXZK-520  
下成型真空包装机  
Molding vacuum machine

抽真空能力 (m³/h) Pump capacity	100/100-160/100-160
生产速度 (uph) Production speed	200-400
外形尺寸 (mm) Dimensions	2700*1030*1900 2700*1130*1900 2700*1230*1900
电源 Power	3P AC380V 50Hz 12/14/16kW
重量 (kg) Weight	1200/1500/1800

## HORIZONTAL PACKAGING MACHINE 枕式包装机



YS-TSB-450 半自动气调保鲜包装机  
YS-VSP-450 半自动贴体包装机  
Semi-automatic modified atmosphere  
packaging machine

气源压力 (MPa) Air pressure	0.6-0.8
生产速度 (uph) Production speed	120-240
外形尺寸 (mm) Dimensions	1800*1400*1750
电源 Power	380V 50Hz 8.0kW (可选其它电压) (other voltage optional)
重量 (kg) Weight	600



YS-TSB-570 全自动气调保鲜包装机  
YS-VSP-570 全自动贴体包装机  
Continuous modified atmosphere  
packaging machine

气源压力 (MPa) Air pressure	0.6-0.8
生产速度 (uph) Production speed	120-240
外形尺寸 (mm) Dimensions	4370*1080*1900
电源 Power	380V 50Hz 8.0kW (可选其它电压) (other voltage optional)
重量 (kg) Weight	1000





YZB 100 上送膜旋转式枕包机  
Flow pack machine

电源 Power	AC380V 50Hz 6.0kW
包装膜材质 Film material	PET/AL/PE, OPP/PE等枕包复合膜 And other complex film for flow pack
包装膜宽 (mm) Film width	120-400
卷膜直径 (mm) Film diameter	300
产品规格 (mm) Products size	L(80-240), W(40-150), H(5-35)
包装速度 (包/分钟) Speed (packs/min)	120
外形尺寸 (mm) Machine size	3260*930*1500
适用产品 Products	外形类似长方体, 散件需有托盒, 例如药板包装 Shaped like a cuboid, the pieces need tray, such as medicine packaging
可选项 Optional	伺服下料机构 Servo feeding mechanism



YZB 100X 下送膜旋转式枕包机  
Flow pack machine

电源 Power	AC380V 50Hz 6.0kW
包装膜材质 Film material	PET/AL/PE, OPP/PE等枕包复合膜 And other complex film for flow pack
包装膜宽 (mm) Film width	240-600
卷膜直径 (mm) Film diameter	300
产品规格 (mm) Products size	L(100-400), W(80-220), H(20-100)
包装速度 (包/分钟) Speed (packs/min)	60
外形尺寸 (mm) Machine size	5535*1235*1540
适用产品 Products	外形类似长方体, 散件需有托盒, 例如药板包装 Shaped like a cuboid, the pieces need tray, such as medicine packaging
输送方向 Direction	自右往左 From right to left



YZB 100H 上送膜旋转式枕包机  
Flow pack machine

电源 Power	AC380V 50Hz 6.5kW
包装膜材质 Film material	PET/AL/PE, OPP/PE等枕包复合膜 And other complex film for flow pack
包装膜宽 (mm) Film width	120-400
卷膜直径 (mm) Film diameter	300
产品规格 (mm) Products size	L(80-240), W(40-150), H(5-70)
包装速度 (包/分钟) Speed (packs/min)	100
外形尺寸 (mm) Machine size	3895*995*1680
适用产品 Products	外形类似长方体, 散件需有托盒, 例如药板包装 Shaped like a cuboid, the pieces need tray, such as medicine packaging



YZB 100XWL 下送膜往复式枕包机  
Flow pack machine

电源 Power	AC380V/220V 50Hz 10.5kW
包装膜材质 Film material	PET/AL/PE, OPP/PE等枕包复合膜 And other complex film for flow pack
包装膜宽 (mm) Film width	240-820
卷膜直径 (mm) Film diameter	300
产品规格 (mm) Products size	L(150-600), W(80-240), H(20-150)
包装速度 (包/分钟) Speed (packs/min)	60
外形尺寸 (mm) Machine size	5505*1385*1630
适用产品 Products	叶蔬菜类产品或长方体类产品 Vegetable or cuboid products
输送方向 Direction	自右往左 From right to left



YZB 100L 上送膜旋转式枕包机  
Flow pack machine

电源 Power	AC380V 50Hz 6.0kW
包装膜材质 Film material	PET/AL/PE, OPP/PE等枕包复合膜 And other complex film for flow pack
包装膜宽 (mm) Film width	240-600
卷膜直径 (mm) Film diameter	300
产品规格 (mm) Products size	L(100-400), W(80-220), H(20-100)
包装速度 (包/分钟) Speed (packs/min)	60
外形尺寸 (mm) Machine size	5535*1235*1540
适用产品 Products	外形类似长方体, 散件需有托盒, 例如药板包装 Shaped like a cuboid, the pieces need tray, such as medicine packaging
输送方向 Direction	自右往左 From right to left



YZB 100WL 上送膜往复式枕包机  
Flow pack machine

电源 Power	AC380V/220V 50Hz 10.5kW
包装膜材质 Film material	PET/AL/PE, OPP/PE等枕包复合膜 And other complex film for flow pack
包装膜宽 (mm) Film width	240-820
卷膜直径 (mm) Film diameter	300
产品规格 (mm) Products size	L(150-600), W(80-240), H(20-150)
包装速度 (包/分钟) Speed (packs/min)	60
外形尺寸 (mm) Machine size	5505*1385*1630
适用产品 Products	托盒蔬菜类产品或长方体类产品 Vegetable or cuboid products
输送方向 Direction	自右往左 From right to left



**YZT 100WL 上送膜往复式枕式套袋机**  
Flow pack machine

电源 Power	AC380V/220V 50Hz 6.5kW
包装膜材质 Film material	POF热缩膜等 POF film
包装膜宽 (mm) Film width	240-640
卷膜直径 (mm) Film diameter	300
产品规格 (mm) Products size	L(100-400), W(60-240), H(20-150)
包装速度 (包/分钟) Speed (packs/min)	80包/分钟 80 packs/min
外形尺寸 (mm) Machine size	4355*1110*1630
适用产品 Products	外形类似长方体, 散件需有托盒, 例如药板包装 Shaped is similar as cuboid, the pieces need tray, such as box instant noodles

**YZT 100XWL 下送膜往复式枕式套袋机**  
Flow pack machine

电源 Power	AC380V/220V 50Hz 6.8kW
包装膜材质 Film material	POF热缩膜等 POF film
包装膜宽 (mm) Film width	300-880
卷膜直径 (mm) Film diameter	300
产品规格 (mm) Products size	L(150-600), W(80-240), H(20-150)
包装速度 (包/分钟) Speed (packs/min)	80
外形尺寸 (mm) Machine size	5505*1385*1715
适用产品 Products	外形类似长方体, 散件需有托盒, 例如药板包装 Shaped is similar as cuboid, the pieces need tray, such as box instant noodles
输送方向 Direction	自右往左 From right to left

**WSA3610/4512/6012 上送膜往复式枕式套袋机**  
Flow pack machine

电源 Power	AC380V 50Hz 6.0kW
包装膜材质 Film material	PET/AL/PE, OPP/PE等枕包复合膜 And other complex film for flow pack
包装膜宽 (mm) Film width	100-360, 100-450, 100-600
卷膜直径 (mm) Film diameter	300
产品规格 (mm) Products size	L(80-300), W(40-100)/150, H(5-50)/70 L(80-400), W(40-250), H(5-100)
包装速度 (包/分钟) Speed (packs/min)	120-150, 100
外形尺寸 (mm) Machine size	4450*950*1750 4650*1050*1750 4800*1200*1800
适用产品 Products	外形类似长方体, 散件需有托盒, 例如药板包装 Shaped is similar as cuboid, the pieces need tray, such as box instant noodles
可选项 Optional	伺服下料机构 Servo feeding mechanism



**ZXA4512/7215/WXA4512 下送膜往复式枕式套袋机**  
Flow pack machine

电源 Power	AC380V 50Hz 6.0kW
包装膜材质 Film material	PET/AL/PE, OPP/PE等枕包复合膜 And other complex film for flow pack
包装膜宽 (mm) Film width	100-450, 100-720, 100-450
卷膜直径 (mm) Film diameter	300
产品规格 (mm) Products size	L(80-300), W(40-150), H(5-50) L(80-400), W(40-300), H(5-100) L(80-300), W(40-150), H(5-70)
包装速度 (包/分钟) Speed (packs/min)	120, 80, 100
外形尺寸 (mm) Machine size	5100*1250*1250 5300*1275*1320 5100*1250*1250
适用产品 Products	外形类似长方体, 散件需有托盒, 例如药板包装 Shaped is similar as cuboid, the pieces need tray, such as box instant noodles
可选项 Optional	伺服下料机构 Servo feeding mechanism

**ZSA4512/4515/6015/6018 上送膜旋转式枕包机**  
Flow pack machine

电源 Power	AC380V 50Hz 6.0kW
包装膜材质 Film material	PET/AL/PE, OPP/PE等枕包复合膜 And other complex film for flow pack
包装膜宽 (mm) Film width	100-450, 100-600
卷膜直径 (mm) Film diameter	300
产品规格 (mm) Products size	L(80-300), W(40-150), H(5-50/75) L(80-400), W(40-250), H(5-70/100)
包装速度 (包/分钟) Speed (packs/min)	100-120, 80-100
外形尺寸 (mm) Machine size	4600*1050*1750 4800*1200*1800
适用产品 Products	外形类似长方体, 散件需有托盒, 例如药板包装 Shaped is similar as cuboid, the pieces need tray, such as box instant noodles
可选项 Optional	伺服下料机构 Servo feeding mechanism



# BLISTER PACKAGING MACHINE

## 泡罩机



YS-DPF260 高速自动铝塑铝泡罩包装机(辊板)  
High speed ALU-PVC-ALU/ALU-PVC(tropical ALU)  
blister packaging machine

电源及功率 Total power	380V 50Hz 28kW
热封加热功率(kW) Heat sealing power	4.5*2
电机总功率(kW) Motor Power	3.5
最大成型面积(mm) Max forming area	250*200
最大成型深度(mm) Max forming depth	铝/塑 12, 铝/铝 10 ALU/PVC 12, ALU/ALU 10
最大冲裁速度 Punch frequency	铝/塑 130组/分, 铝/铝 80组/分(标准版) ALU/PVC 130 blister sheets/min ALU/ALU 80 blister sheets/min (standard)
包装材料规格(mm) Packing material	药用PVC 260*0.25(0.15-0.5), 热封铝箔 PTP 260*0.02, 冷成型铝 260*0.12 Poison-free PVC 260*0.25(0.15-0.5), PTP 260*0.02, cold forming ALU foll 260*0.12
冷却水耗量(m <sup>3</sup> /h) Mould cooling	0.8(循环水冷水机) (tap water or recycle water)
气源压力(MPa) Air pressure	0.6-0.8
整机外形尺寸(mm) Machine overall dimension	4972*1220*2000(含料斗) (including feeding hopper)
整机重量(kg) Machine weight	2600

YS-DPH260 高速自动铝塑泡罩包装机(辊板)  
High speed ALU-PVC(tropical ALU) blister  
packaging machine

电源及功率 Total power	380V 50Hz 20kW
热封加热功率(kW) Heat sealing power	4.5*2
电机总功率(kW) Motor Power	3.5
最大成型面积(mm) Max forming area	250*200
最大成型深度(mm) Max forming depth	铝/塑 12 ALU/PVC 12
最大冲裁速度 Punch frequency	铝/塑 130组/分 ALU/PVC 130 blister sheets/min
包装材料规格(mm) Packing material	药用PVC 260*0.25(0.15-0.5) 热封铝箔 PTP 260*0.02 Poison-free PVC 260*0.25(0.15-0.5) PTP 260*0.02
冷却水耗量(m <sup>3</sup> /h) Mould cooling	0.8(循环水冷水机) (tap water or recycle water)
气源压力(MPa) Air pressure	0.6-0.8
整机外形尺寸(mm) Machine overall dimension	3465*1130*2000(含料斗) (including feeding hopper)
整机重量(kg) Machine weight	2100



YS-DPH300A 高速自动铝塑泡罩包装机(辊板)  
High speed ALU-PVC(tropical ALU)  
blister packaging machine

电源及功率 Total power	380V 50Hz 26kW
热封加热功率 (kW) Heat sealing power	4.5*2
电机总功率 (kW) Motor Power	4
最大成型面积 (mm) Max forming area	290×200
最大成型深度 (mm) Max forming depth	铝/塑 12 ALU/PVC 12
最大冲裁速度 Punch frequency	铝/塑 180组/分 ALU/PVC 180 blister sheets/min
包装材料规格 (mm) Packing material	药用PVC 300*0.25(0.15-0.5) 热封铝箔 PTP 300*0.02 Poison-free PVC 300*0.25(0.15-0.5) PTP 300*0.02
冷却水耗量 (m³/h) Mould cooling	0.8 (循环水冷水机) (tap water or recycle water)
气源压力 (MPa) Air pressure	0.6-0.8
整机外形尺寸 (mm) Machine overall dimension	3700*1102*2090 (含料斗) (including feeding hopper)
整机重量 (kg) Machine weight	2100



YS-DPT350 高速自动制托泡罩包装机(平板)  
High speed ALU-PVC(tropical ALU)  
blister packaging machine

电源及功率 Total power	380V 50Hz 15kW
成型上下加热功率 (kW) Forming heating power	3.5*2
电机总功率 (kW) Motor Power	6
最大成型面积 (mm) Max forming area	290*200
最大成型深度 (mm) Max forming depth	12
最大冲裁速度 (mm) Punch frequency	30
包装材料规格 (mm) Packing material	药用PVC 300*0.25(0.15-0.5) Poison-free PVC 300*0.25(0.15-0.5)
冷却水耗量 (m³/h) Mould cooling	0.8 (循环水冷水机) (tap water or recycle water)
气源压力 (MPa) Air pressure	0.6-0.8
整机外形尺寸 (mm) Machine overall dimension	3460*1050*2000 (含料斗) (including feeding hopper)
整机重量 (kg) Machine weight	2100



YS-DPH300 高速自动铝塑泡罩包装机(辊板)  
High speed ALU-PVC(tropical ALU)  
blister packaging machine

电源及功率 Total power	380V 50Hz 26kW
热封加热功率 (kW) Heat sealing power	4.5*2
电机总功率 (kW) Motor Power	4
最大成型面积 (mm) Max forming area	290*200
最大成型深度 (mm) Max forming depth	铝/塑 12 ALU/PVC 12
最大冲裁速度 Punch frequency	铝/塑 180组/分 ALU/PVC 180 blister sheets/min
包装材料规格 (mm) Packing material	药用PVC 300*0.25(0.15-0.5) 热封铝箔 PTP 300*0.02 Poison-free PVC 300*0.25(0.15-0.5) PTP 300*0.02
冷却水耗量 (m³/h) Mould cooling	0.8 (循环水冷水机) (tap water or recycle water)
气源压力 (MPa) Air pressure	0.6-0.8
整机外形尺寸 (mm) Machine overall dimension	3552*1102*2090 (含料斗) (including feeding hopper)
整机重量 (kg) Machine weight	2100

泡罩包装机+蜘蛛手+装盒机+捆扎机 生产线  
Full Automatic High Speed Blister Packing Machine And Cartoning Machine Production Line



# CARTONING MACHINE

## 装盒机



YCZ-125B 全自动装盒机 (装板)  
Automatic cartoning machine (for blisters)

电源及功率 Total Power	3P AC380V 50Hz 1.5kW
气源压力 (MPa) Air Pressure	0.6-0.8
耗气量 (L/min) Air Consumption	20-30
外形尺寸 (mm) Machine Dimension	1900*1050*1760
生产能力 (boxes/min) Production capacity	30-100 (根据实际产品确定) (depends on the actual material)
盒子尺寸 (mm) Size of box	L(65-125)*W(30-83)*H(20-53)/(10-43)
封盒方式 Sealing type	插舌或喷胶 Cartoning folding or nordson gluing



全自动装盒机  
Automatic cartoning machine

型号 Model	YCZ-125G 带挡板型 With in-feed baffle	YCZ-125K 针剂型 For injection medicines	YCZ-125P 瓶装 For bottle
电源及功率 Total power	3P AC380V 50Hz 1.5kW	3P AC380V 50Hz 1.5kW	3P AC380V 50Hz 1.5kW
气源压力 (MPa) Air pressure	0.6-0.8	0.6-0.8	0.6-0.8
耗气量 (L/min) Air consumption	20-30	20-30	20-30
外形尺寸 (mm) Machine dimension	2800*1100*1760	2600*1150*1760	2680*1080*1760
生产能力 (boxes/min) Production capacity	30-85 (根据实际产品确定) (depends on the actual material)	30-85 (根据实际产品确定) (depends on the actual material)	30-100 (根据实际产品确定) (depends on the actual material)
盒子尺寸 (mm) Size of box	L(120-165)/(65-125)/(48-65)* W(30-83)*H(20-53)/(10-43)	L(120-165)*W(30-83) *H(20-53)/(13-43)	L(65-125)*W(30-83)*H(20-53)



YCZ-130 全自动装盒机  
Full automatic cartoning machine

电源及功率 Total power	3P AC380V 50Hz 1.5kW
气源压力 (MPa) Air pressure	0.6-0.8
耗气量 (L/min) Air consumption	20-30
外形尺寸 (mm) Machine dimension	L2300*W1200*H1650
生产能力 (boxes/min) Production capacity	30-130 (根据实际产品确定) (depends on the actual material)
盒子尺寸 (mm) Size of box	插舌或喷胶 Cartoning folding or nordson gluing



YCZ-120S 全自动装盒机  
Full automatic cartoning machine

电源及功率 Total power	3P AC380V 50Hz 7kW
气源压力 (MPa) Air pressure	0.6-0.8
耗气量 (L/min) Air consumption	15-20
外形尺寸 (mm) Machine dimension	4500*1300*1750
生产能力 (boxes/min) Production capacity	30-100 (根据实际产品确定) (depends on the actual material)
封盒方式 Sealing type	喷胶 Nordson gluing
进料方式 Feeding mode	直线方式 Straight line



YCZ-150 全自动装盒机  
Full automatic cartoning machine

电源及功率 Total power	3P AC380V 50Hz 8.5kW
气源压力 (MPa) Air pressure	0.6-0.8
耗气量 (L/min) Air consumption	15-20
外形尺寸 (mm) Machine dimension	4200*1250*1800
生产能力 (boxes/min) Production capacity	50-150 (根据实际产品确定) (depends on the actual material)
封盒方式 Sealing type	插舌或喷胶 Cartoning folding or nordson gluing



YCZ-200 全自动装盒机  
Full automatic cartoning machine

电源及功率 Total power	3P AC380V 50Hz 10.5kW
气源压力 (MPa) Air pressure	0.6-0.8
耗气量 (L/min) Air consumption	15-20
外形尺寸 (mm) Machine dimension	4500*1450*1700
生产能力 (boxes/min) Production capacity	100-180 (根据实际产品确定) (depends on the actual material)
封盒方式 Sealing type	插舌或喷胶 Cartoning folding or nordson gluing



YCZ-300 全自动装盒机  
Full automatic cartoning machine

电源及功率 Total power	3P AC380V 50Hz 15.5kW
气源压力 (MPa) Air pressure	0.6-0.8
耗气量 (L/min) Air consumption	15-20
外形尺寸 (mm) Machine dimension	4500*1450*1800
生产能力 (boxes/min) Production capacity	200-260 (根据实际产品确定) (depends on the actual material)
封盒方式 Sealing type	插舌或喷胶 Cartoning folding or nordson gluing



YCK-400 全自动薄膜捆扎机  
Automatic film banding machine  
YCK-200 全自动薄膜捆扎机  
Automatic film banding machine

电源及功率 Total power	AC220V 50Hz 2.0kW
气源压力 (MPa) Air pressure	0.6-0.8
耗气量 (L/min) Air consumption	5-8
外形尺寸 (mm) Machine dimension	2400*980*1780
包装方式 Pack format	1*5, 1*10, 2*5
生产能力 (bags/min) Production capacity	15-20 (根据实际产品确定) (depends on the actual material)
最大包装物尺寸 (mm) Max pack size	160*120*300
盒子规格 (mm, g/m <sup>2</sup> ) Specification of box	L(80-160)*W(30-120)*H(15-50)/(250-350)



BZTZ-40 透明膜三维包装机  
Cellophane wrapping machine  
BZTZ-80 透明膜三维包装机  
Cellophane wrapping machine

电源及功率 Total Power	AC220V/380V 50Hz 4.0kW
气源压力 (MPa) Air Pressure	0.6-0.8
外形尺寸 (mm) Machine Dimension	2100* 820*1700
包装规格 (mm) Pack size range	L(110-300)*W(55-200)*H(30-100)
包装速度 (bags/min) Production capacity	20-40
卷膜规格 (mm) Specification of Roll film	内径Φ75, 外径Φ300, 宽度≤430(根据产品大小选择) Inner dia.Φ75, outer dia.Φ300, width≤430 (depends on the actual material)
卷膜材质 Material of Roll film	PVC或BOPP双面热封薄膜, 热封温度100-160°C PVC or BOPP(two-side heat sealable), temperature of heat sealing 100-160°C

# SHRINK WRAPPING MACHINE

## 套袋膜包热收缩机

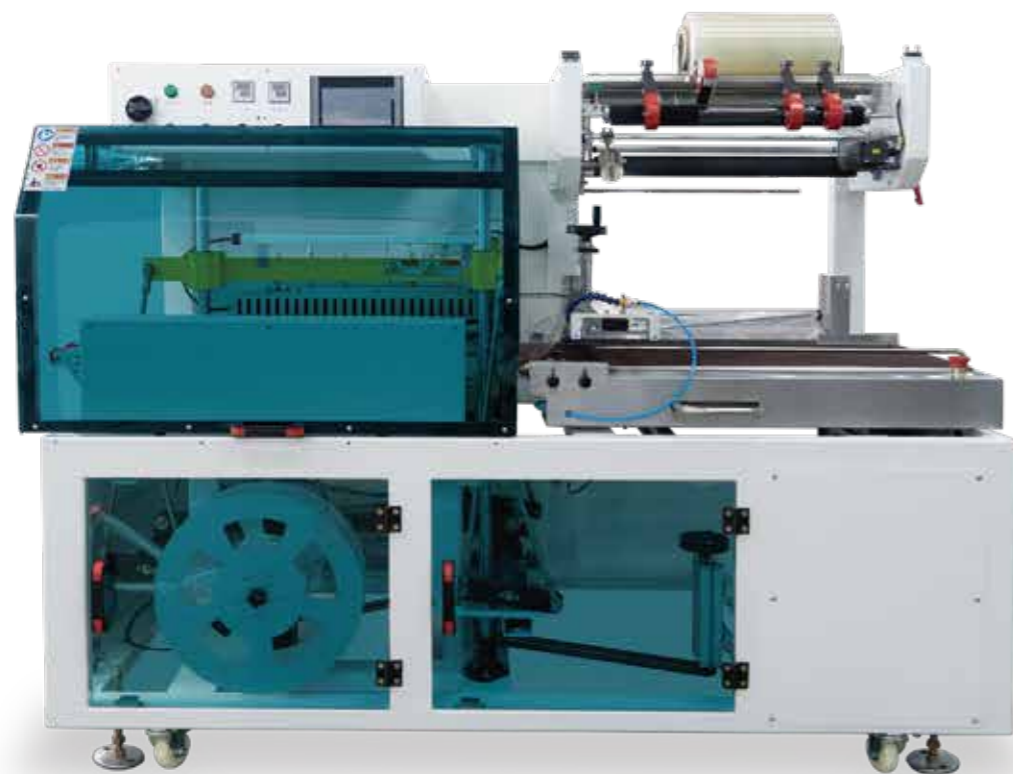

YS-ZB-3246 手动套袋热收缩一体  
Manual Shrink Wrapping Machine

电源 Power	1P AC220V 50Hz 2.1kW
工作台面高度 (mm) Working table height	920
净重 (kg) Machine weight	71
封边方式 Sealing system	底部刀片 Bottom sealing
包装速度 (pcs/min) Speed	4-8
机器尺寸 (mm) Machine dimension	650*1120
适用膜卷尺寸 (mm) Film size	Φ250*W470
最大封口尺寸 (mm) Max sealing size	320*460
最大包装尺寸 (mm) Max packing size	L<410, W<270, H<150 & W+H<350
可选项 Optional	废膜卷绕器 Waste film winder

YS-ZB-4255MINI 手动套袋热收缩一体  
Manual Shrink Wrapping Machine



电源 Power	1P AC220V 50Hz 3.0kW
工作台面高度 (mm) Working table height	920
净重 (kg) Machine weight	90
封边方式 Sealing system	底部刀片 Bottom sealing
包装速度 (pcs/min) Speed	4-8
机器尺寸 (mm) Machine dimension	680*1370
适用膜卷尺寸 (mm) Film size	Φ250*W520
最大封口尺寸 (mm) Max sealing size	420*550
最大包装尺寸 (mm) Max packing size	L<500, W<370, H<150 & W+H<450
可选项 Optional	废膜卷绕器, 输送滚筒, 动力输送网带 Waste film winder, roller conveyor, conveyor belt

YS-ZB-6084 手动套袋热收缩一体  
Manual Shrink Wrapping Machine



电源 Power	3P AC380V 50Hz 7.0kW
工作台面高度 (mm) Working table height	920
净重 (kg) Machine weight	180
封边方式 Sealing system	底部刀片 Bottom sealing
包装速度 (pcs/min) Speed	4-8
机器尺寸 (mm) Machine dimension	950*1870
适用膜卷尺寸 (mm) Film size	Φ250*W820
最大封口尺寸 (mm) Max sealing size	600*840
最大包装尺寸 (mm) Max packing size	L<790, W<550, H<180 & W+H<630
可选项 Optional	废膜卷绕器 Waste film winder



**YS-SL-6045B 半自动套袋机 (气动)**  
Semi-automatic shrink wrapping machine (pneumatic)

电源 Power	1P AC220V 50Hz 1.0kW
气源 (MPa) Air pressure	0.6-0.8
工作台面高度 Working table height	780
封边方式 Sealing system	底部刀片 Bottom sealing
包装速度 (pcs/min) Speed	8-15
机器尺寸 (mm) Machine dimension	1510*830
适用膜卷尺寸 (mm) Film size	Φ250*W640
最大封口尺寸 (mm) Max sealing size	580*430
最大包装尺寸 (mm) Max packing size	L<530, W<380, H<150 & W+H<460
备注说明 Remarks	配套的热收缩机 YS-ST-5025 With tunnel



**YS-RS-5/YS-SM-4525 热收缩机**  
Tunnel

电源 Power	3P AC380V 50Hz 7.0/13.0kW
工作台面高度 (mm) Working table height	780/800
机器尺寸 (mm) Machine dimension	1600*850*1400 1300*680*1460
炉腔进口尺寸 (mm) Furnace size	470*220 450*250
炉腔长度 (mm) Furnace length	1100 1000
输送速度 (m/min) Speed	0-12, 0-10
适用膜的种类 Film material	POF, PVC, PE
备注说明 Remarks	配套的套袋机为 YS-FL-5545 With shrink wrapping machine



**YS-FL-5545A/YS-FL-7555A 半自动套袋机 (手动)**  
Semi-automatic shrink wrapping machine (manual)

电源 Power	1P AC220V 50Hz 1.0kW
气源 (MPa) Air pressure	0.6-0.8
工作台面高度 Working table height	800
封边方式 Sealing system	顶部刀片 Top sealing
包装速度 (pcs/min) Speed	8-15
机器尺寸 (mm) Machine dimension	1600*680
适用膜卷尺寸 (mm) Film size	Φ250*W530
最大封口尺寸 (mm) Max sealing size	550*450
最大包装尺寸 (mm) Max packing size	L<500, W<400, H<150 & W+H<480
备注说明 Remarks	配套的热收缩机 YS-SM-4525 With tunnel



**YS-ZJ-2 热收缩机**  
Tunnel

电源 Power	3P AC380V 50Hz 24.0kW
工作台面高度 (mm) Working table height	750
机器尺寸 (mm) Machine dimension	2600*1300*1600
炉腔进口尺寸 (mm) Furnace size	600*400
炉腔长度 (mm) Furnace length	2000
输送速度 (m/min) Speed	0-18
适用膜的种类 Film material	POF, PVC, PE
备注说明 Remarks	配套的套袋机为 YS-ZB-1, YS-ZB-2, YS-ZB-3, YS-ZB-4 With shrink wrapping machine



**YS-FT-4520 热收缩机**  
Tunnel

电源 Power	3P AC380V 50Hz 10.0kW
工作台面高度 (mm) Working table height	780
机器尺寸 (mm) Machine dimension	1800*850*1500
炉腔进口尺寸 (mm) Furnace size	450*200
炉腔长度 (mm) Furnace length	1400
输送速度 (m/min) Speed	0-12
适用膜的种类 Film material	POF, PE
备注说明 Remarks	配套的套袋机为 YS-ZB-5AX, YS-ZB-5AB With shrink wrapping machine



**YS-FT-4525 热收缩机**  
Tunnel

电源 Power	3P AC380V 50Hz 24.0kW
工作台面高度 (mm) Working table height	850
机器尺寸 (mm) Machine dimension	1800*980*1320
炉腔进口尺寸 (mm) Furnace size	600*400
炉腔长度 (mm) Furnace length	1500
输送速度 (m/min) Speed	0-18
适用膜的种类 Film material	POF, PVC, PE
备注说明 Remarks	配套的套袋机为 YS-ZB-5B, YS-ZB-5C, YS-ZB-5D, YS-ZB-5E With shrink wrapping machine



**YS-ZB-5AB 全自动套袋机**  
Automatic shrink wrapping machine

电源 Power	1P AC220V 50Hz 3.0kW
压缩空气压力 (MPa) Air pressure	0.6-0.8
工作台面高度 (mm) Working table height	780
包装速度 (pcs/min) Speed	10-35
最大封边尺寸 (mm) Max sealing size	∞*450
最大包装物体尺寸 (mm) Max packing size	W+H<400, 且H<150
适用膜卷尺寸 (mm) Film size	Φ280*W550
机器尺寸 (mm) Machine dimension	1670*780*1520
选配 Optional	密接伸缩皮带 Intimate contact flexible belt



**YS-ZB-5B 全自动套袋机**  
Automatic shrink wrapping machine

电源 Power	3P AC380V 50Hz 3.7kW
压缩空气压力 (MPa) Air pressure	0.6-0.8
工作台面高度 (mm) Working table height	850
包装速度 (pcs/min) Speed	1-55
最大封边尺寸 (mm) Max sealing size	W<380 (可定制), L(∞) (Customized)
最大包装物体尺寸 (mm) Max packing size	W+H<420, 且H<150
适用膜卷尺寸 (mm) Film size	Φ280*W550
机器尺寸 (mm) Machine dimension	2080*1500*1300



**YS-ZB-5AD 全自动套袋机**  
Automatic shrink wrapping machine

电源 Power	1P AC220V 50Hz 3.0kW
压缩空气压力 (MPa) Air pressure	0.6-0.8
工作台面高度 (mm) Working table height	780
包装速度 (pcs/min) Speed	1-60
最大封边尺寸 (mm) Max sealing size	550*450
最大包装物体尺寸 (mm) Max packing size	L+H<500, W+H<400, H<150
适用膜卷尺寸 (mm) Film size	Φ280*W550
机器尺寸 (mm) Machine dimension	1920*900*1520(可定制) (Customized)
选配 Optional	密接伸缩皮带 Intimate contact flexible belt



**YS-ZB-5C 全自动套袋机**  
Automatic shrink wrapping machine

电源 Power	3P AC380V 50Hz 4.0kW
压缩空气压力 (MPa) Air pressure	0.6-0.8
工作台面高度 (mm) Working table height	850
包装速度 (pcs/min) Speed	1-25
最大封边尺寸 (mm) Max sealing size	W<390 (可定制), L(∞) (Customized)
最大包装物体尺寸 (mm) Max packing size	W+H<450, 且H<250
适用膜卷尺寸 (mm) Film size	Φ280*W550
机器尺寸 (mm) Machine dimension	2780*1500*1300



**YS-ZB-5AX 全自动套袋机**  
Automatic shrink wrapping machine

电源 Power	1P AC220V 50Hz 3.0kW
压缩空气压力 (MPa) Air pressure	0.6-0.8
工作台面高度 (mm) Working table height	780
包装速度 (pcs/min) Speed	10-35
最大封边尺寸 (mm) Max sealing size	550*450
最大包装物体尺寸 (mm) Max packing size	L+H<500, W+H<400, H<120
适用膜卷尺寸 (mm) Film size	Φ280*W550
机器尺寸 (mm) Machine dimension	1670*780*1520
选配 Optional	密接伸缩皮带 Intimate contact flexible belt



**YS-ZB-5D 全自动套袋机**  
Automatic shrink wrapping machine

电源 Power	3P AC380V 50Hz 3.0kW
压缩空气压力 (MPa) Air pressure	0.6-0.8
工作台面高度 (mm) Working table height	850
包装速度 (pcs/min) Speed	1-35
最大封边尺寸 (mm) Max sealing size	500*600
最大包装物体尺寸 (mm) Max packing size	W<400, L<500, H<200, 且W+H<500
适用膜卷尺寸 (mm) Film size	Φ280*W600
机器尺寸 (mm) Machine dimension	2150*1500*1400



YS-ZB-5E 全自动套袋机  
Automatic shrink wrapping machine

电源 Power	3P AC380V 50Hz 4.5kW
气源压力 (MPa) Air pressure	0.6-0.8
工作台面高度 (mm) Working table height	850
包装速度 (pcs/min) Speed	1-60
最大封边尺寸 (mm) Max sealing size	380(W)*∞(L)
最大包装物体尺寸 (mm) Max packing size	W+H<420, 且H<120
适用膜卷尺寸 (mm) Film size	Φ250*W550
机器尺寸 (mm) Machine dimension	2580*1520*1320



YS-ZB-3 套袋机  
Shrink wrapping machine

电源 Power	3P AC380V 50Hz 3.0kW
气源压力 (MPa) Air pressure	0.6-0.8
包装形式 Packaging form	袖口封闭式 Closed type
工作速度 (packages/min) Speed	1-12
工作台面高度 (mm) Working table height	850 (可定制) (Customized)
薄膜规格 (mm) Film size	PE等收缩膜, 厚0.04-0.10 PE etc., thickness 0.04-0.10
机器尺寸 (mm) Machine dimension	1200*1500*1950



YS-ZB-1 套袋机  
Shrink wrapping machine

电源 Power	3P AC380V 50Hz 2.0kW
气源压力 (MPa) Air pressure	0.6-0.8
包装形式 Packaging form	袖口封闭式 Closed type
工作速度 (packages/min) Speed	1-15
工作台面高度 (mm) Working table height	850 (可定制) (Customized)
薄膜规格 (mm) Film size	PE等收缩膜, 厚0.04-0.10 PE etc., thickness 0.04-0.10
机器尺寸 (mm) Machine dimension	1290*1000*2000



YS-ZB-4 套袋机  
Shrink wrapping machine

电源 Power	3P AC380V 50Hz 5kW
气源压力 (MPa) Air pressure	0.6-0.8
包装形式 Packaging form	袖口半封闭式或全封闭式 Closed type
工作速度 (packages/min) Speed	6-12
包装物体尺寸 (mm) Sealing parameter	长方体, 最大宽度为1200, 高度500 Rectangular object, maximum width is 1200, height is 500
工作台面高度 (mm) Working table height	750 (可根据需要定制) (Customized)
薄膜规格 (mm) Film size	PE等收缩膜, 厚0.04-0.10 PE etc., thickness 0.04-0.10



YS-ZB-2 套袋机  
Shrink wrapping machine

电源 Power	3P AC380V 50Hz 2.5kW
气源压力 (MPa) Air pressure	0.6-0.8
包装形式 Packaging form	袖口封闭式 Closed type
工作速度 (packages/min) Speed	1-20
工作台面高度 (mm) Working table height	750 (可定制) (Customized)
薄膜规格 (mm) Film size	PE等收缩膜, 厚0.04-0.10 PE etc., thickness 0.04-0.10
机器尺寸 (mm) Machine dimension	1500*920*2000



YS-ZB-4C 单片膜裹包机  
Shrink wrapping machine

电源 Power	三相五线制 AC380V±10% 50Hz 3P5wires AC380V±10% 50Hz
控制电源 Control power	24V DC
气源压力 (MPa) Air pressure	0.6-0.8
机器尺寸 (mm) Machine dimension	7530*1670*2508 (可定制) (Customized)
包装速度 (packages/min) Speed	30
瓶型尺寸(L/mm) Bottle capacity	0.25-5 Φ45-120, H90-350
瓶型 Bottle material	玻璃瓶、易拉罐、PE/PET瓶 Glass bottles, cans, PE/PET bottles
工作台面高度 (mm) Working table height	1150±50 (可定制) (customized)



**YS-ZB-4C-I A 单通道垫纸片膜包机**  
Pad shrink wrapping machine

电源 Power	三相五线制 AC380V±10% 50Hz 3P5wires AC380V±10% 50Hz
控制电源 Control power	24V DC
气源压力 (MPa) Air pressure	0.6-0.8
机器尺寸 (mm) Machine dimension	11290*1670*2508 (可定制) (Customized)
包装速度 (packages/min) Speed	40
瓶型尺寸(L/mm) Bottle capacity	0.25-5 Φ52-120, H120-300
瓶型 Bottle material	玻璃瓶、易拉罐、PE/PET瓶 Glass bottles, cans, PE/PET bottles
工作台面高度 (mm) Working table height	1150±50(可定制) (Customized)

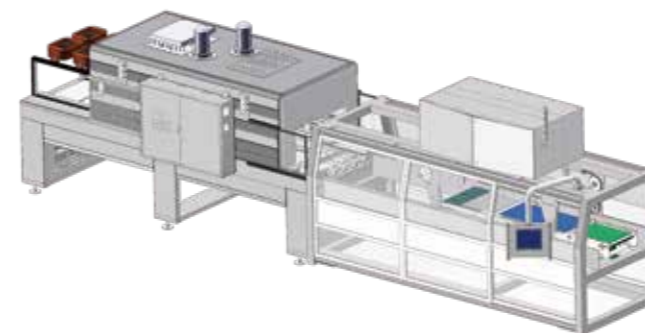

**YS-ZB-6 I (ZX) 纸箱膜包机**  
Wrap around carton machine

电源 Power	三相五线制 AC380V±10% 50Hz 3P5wires AC380V±10% 50Hz
气源压力 (MPa) Air pressure	0.6-0.8
机器尺寸 (mm) Machine dimension	4360*1670*2508 (可定制) (Customized)
包装速度 (packages/min) Speed	45
包装物体尺寸 Objects Size	可定制 Customized
薄膜参数 (mm) Film parameters	透明及白色PE膜 (彩色可选), 厚0.06-0.1 Transparent and white PE film (Color optional), 0.06-0.1 thick
工作台面高度 (mm) Working table height	1150±50 (可定制) (Customized)



**YS-ZB-6 I A 单通道垫纸片膜包机**  
Pad shrink wrapping machine with one lane  
**YS-ZB-6 II A 双通道垫纸片膜包机**  
Pad shrink wrapping machine with two lanes

电源 Power	三相五线制 AC380V±10% 50Hz 3P5wires AC380V±10% 50Hz
控制电源 Control power	24V DC
气源压力 (MPa) Air pressure	0.6-0.8
机器尺寸 (mm) Machine dimension	8800*1670*2508 (可定制) (Customized)
包装速度 (packages/min) Speed	0.5L 45/40(80/90) 1.0L 45(70)
瓶型尺寸(L/mm) Bottle capacity	0.25-5 Φ50-120, H90-300
瓶型 Bottle material	玻璃瓶、易拉罐、PE/PET瓶 Glass bottles, cans, PE/PET bottles
工作台面高度 (mm) Working table height	1150±50(可定制) (Customized)



**YS-ZJ-06-I(L/H)单通道热收缩机(低速/高速)**  
Tunnel with one lane (Low/High speed)  
**YS-ZJ-06-II(L/H)双通道热收缩机(低速/高速)**  
Tunnel with two lanes (Low/High speed)

电源 Power	三相五线制 AC380V±10% 50Hz 3P5wires AC380V±10% 50Hz
加热总功率 (kW) Heating power	91.5, 加热管56根, 每根1.5 91.5, 56 heating tubes, 1.5 each 116, 加热管54根, 每根2.0 116, 54 heating tubes, 2.0each
机器尺寸 (mm) Furnace size	4550*1570*2400 (可定制)(Customized) 6000*1570*2400 (可定制)(Customized)
炉腔尺寸 (mm) Furnace size	3000*1360*990 (可定制)(Customized) 4000*1360*990 (可定制)(Customized)
炉腔进出口网带尺寸 Mesh belt size (mm)	单通道710 (双通道860) Single channel 710 (Double channel 860)
工作台面高度 (mm) Working table height	1150±50 (可定制) (Customized)
输送速度 (m/min) Speed	0-18

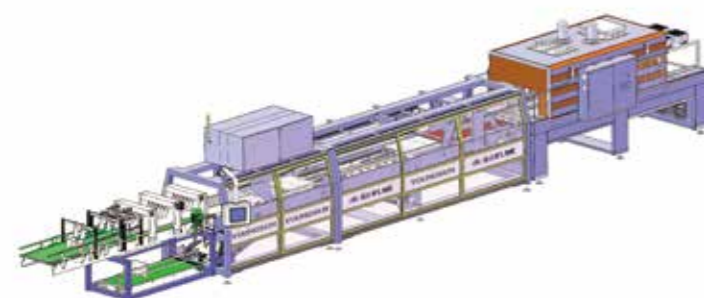

**YS-ZB-6 I B 半托膜包机**  
Tray shrink wrapping machine

电源 Power	三相五线制 AC380V±10% 50Hz 3P5wires AC380V±10% 50Hz
控制电源 Control power	24V DC
气源压力 (MPa) Air pressure	0.6-0.8
机器尺寸 (mm) Machine dimension	11290*1670*2508 (可定制) (Customized)
包装速度 (packages/min) Speed	40
瓶型尺寸(L/mm) Bottle capacity	0.25-5 Φ52-120, H120-300
瓶型 Bottle material	玻璃瓶、易拉罐、PE/PET瓶 Glass bottles, cans, PE/PET bottles
工作台面高度 (mm) Working table height	1150±50(可定制) (Customized)



**YS-ZJ-04-I 单通道热收缩机**  
Tunnel with one lane

电源 Power	三相五线制 AC380V±10% 50Hz 3P5wires AC380V±10% 50Hz
加热总功率 (kW) Heating power	60, 加热管27根, 每根2.0 60, 27 heating tubes, 2.0 each
机器尺寸 (mm) Furnace size	3500*1570*2400 (可定制) (Customized)
炉腔尺寸 (mm) Furnace size	2300*1360*990 (可定制) (Customized)
炉腔进出口网带尺寸 Mesh belt size (mm)	710
工作台面高度 (mm) Working table height	1150±50 (可定制) (Customized)
输送速度 (m/min) Speed	0-18

# WRAP AROUND CASE PACKER 纸包机



YS-ZX-10T 半托纸包机  
Half bracket wrap around case packer

电源 Power	380V±10% (50Hz 3PH+PE), 约10kW 380V±10% (50Hz 3PH+PE), about 10kW
气源压力 (MPa) Air pressure	0.6-0.8
最大产能 (boxes/min) Maximum capacity	17 (根据产品不同有变化) (According to product)
外形尺寸 (mm) Machine dimension	6530*2294*1900

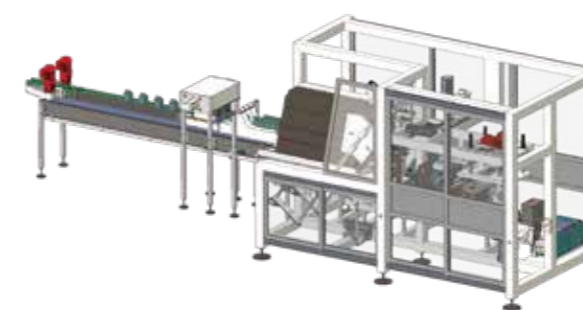

YS-ZX-15T 侧进式纸包机  
Side entry type wrap around case packer

电源 Power	380V±10% (50Hz 3PH+PE), 约11kW 380V±10% (50Hz 3PH+PE), about 11kW
气源压力 (MPa) Air pressure	0.6-0.8
最大产能 (boxes/min) Maximum capacity	15 (根据产品不同有变化) (According to product)
外形尺寸 (mm) Machine dimension	9138*2499*2655



YS-ZX-20T (30T) 下落式纸包机  
Falling type wrap around case packer

电源 Power	380V±10% (50Hz 3PH+PE), 约10(12.5)kW 380V±10% (50Hz 3PH+PE), about 10(12.5)kW
气源压力 (MPa) Air pressure	0.6-0.8
最大产能 (boxes/min) Maximum capacity	20(23) (根据产品不同有变化) (According to product)
外形尺寸 (mm) Machine dimension	7480*2234*1900 (7433*2779*2092)



YS-ZX-35S 纸包机  
wrap around case packer

电源 Power	3P 380V±10% 50Hz
气源压力 (MPa) Air pressure	0.6-0.8
最大产能 (boxes/min) Maximum capacity	32 (根据产品不同有变化) (According to product)
外形尺寸 (mm) Machine dimension	9241*3726*2562



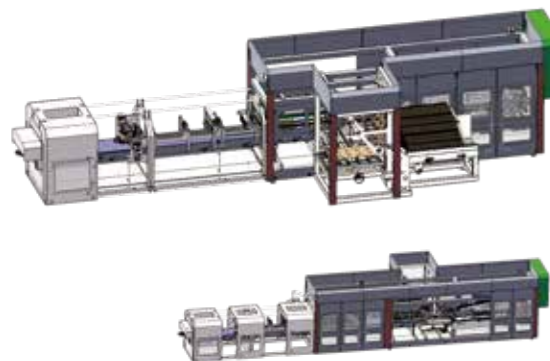

YS-ZX-35TA 直进式纸包机  
Straight type wrap around case packer  
YS-ZX-35TB 直进式纸包机  
Straight type wrap around case packer

电源 Power	380V±10% (50Hz 3PH+PE), 约19(22)kW 380V±10% (50Hz 3PH+PE), about 19(22)kW
气源压力 (MPa) Air pressure	0.6-0.8
最大产能 (boxes/min) Maximum capacity	26 (根据产品不同有变化) (According to product)
外形尺寸 (mm) Machine dimension	9860*2830*2430 (12500*2830*2384)



YS-ZX-50T (GD) 纸包机  
wrap around case packer

电源 Power	3P 380V±10% 50Hz
气源压力 (MPa) Air pressure	0.6-0.8
最大产能 (boxes/min) Maximum capacity	50(根据产品不同有变化) (According to product)
外形尺寸 (mm) Machine dimension	17361*1790*2562

YS-ZX-60TA 纸包机 (同步带摩擦分纸片)  
wrap around case packer  
YS-ZX-60TB 纸包机 (立放纸板吸盘分纸片)  
wrap around case packer

电源 Power	3P 380V±10% 50Hz
气源压力 (MPa) Air pressure	0.6-0.8
最大产能 (packages/min) Maximum capacity	55 (根据产品不同有变化) (According to product)
外形尺寸 (mm) Machine dimension	12944*3726*2562

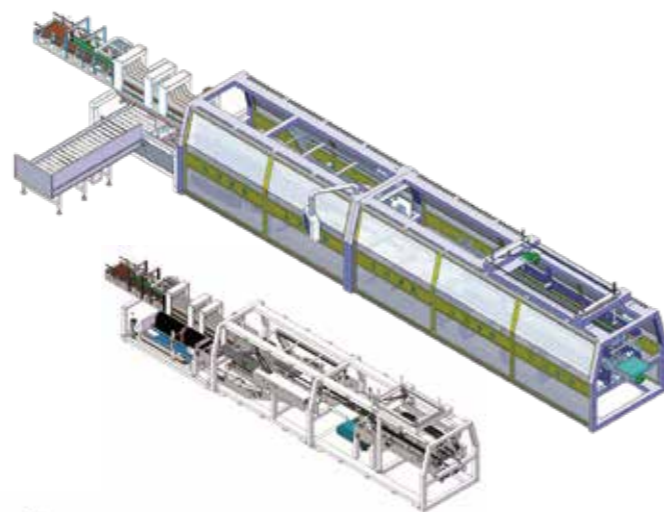

YS-ZX-70TA 纸包机  
wrap around case packer  
YS-ZX-70TB 纸包机  
wrap around case packer

电源 Power	3P 380V±10% 50Hz
气源压力 (MPa) Air pressure	0.6-0.8
最大产能 (packages/min) Maximum capacity	65 (根据产品不同有变化) (According to product)
外形尺寸 (mm) Machine dimension	15035*3726*2562 (14539*3726*2562)

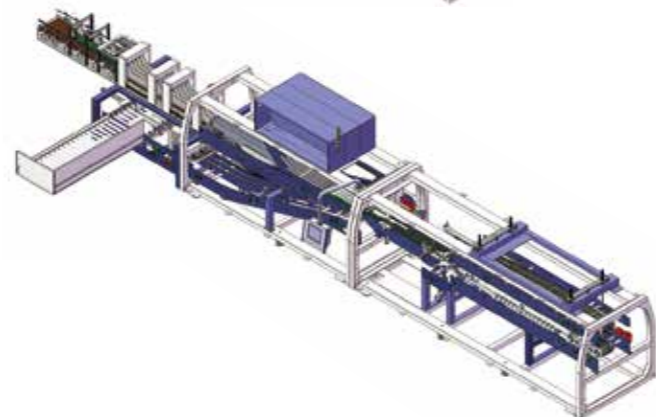

## CARTON ERECTOR 纸箱成型机





CF-10T 半自动纸箱成型机  
Semi-automatic carton erector  
CF-10TX 半自动纸箱成型机  
Semi-automatic carton erector

气源压力 (MPa) Air pressure	0.6-0.8
外形尺寸 (mm) Machine dimension	1500*950*H (台面高+170) H (Working table height +170)
机器重量 (kg) Machine weight	80
纸箱规格 (mm) Carton Size	L200-600, W185-480, H120-480
工作台面高度 (mm) Working table height	600-780 (脚杯), 700-880 (脚轮) 600-780 (Stand), 700-880 (Castor)



CF-30T-F 纸箱成型机 (胶带)  
Carton erector (Adhesive tape)  
CF-30T-H 纸箱成型机 (热熔胶)  
Carton erector (Hot melt adhesive)

电源 Power	380V 50Hz 1.5KW
气源压力 (MPa) Air pressure	0.6-0.8
外形尺寸 (mm) Machine dimension	2700*1560*2300
机器重量 (kg) Machine weight	1100
胶带宽度 (mm) Tape width	48-72
工作速度 (boxes/min) Speed	28

CF-20TX 纸箱成型机  
Carton erector

电源 Power	220V 50Hz 500W
气源压力 (MPa) Air pressure	0.6-0.8
外形尺寸 (mm) Machine dimension	2450*1950*1500
机器重量 (kg) Machine weight	450
胶带宽度 (mm) Tape width	48-72
工作速度 (boxes/min) Speed	10 (标准箱) (Standard box)
选配 (mm) Selection	平储料台 (2550*2750*1500) Storage platform



CF-40T-D 纸箱成型机 (胶带+4个伺服)  
Carton erector (Adhesive tape + 4 servo)  
CF-40T-F 纸箱成型机 (胶带+1个伺服)  
Carton erector (Adhesive tape + 1 servo)  
CF-40T-GS 纸箱成型机 (胶带+3个伺服)  
Carton erector (Adhesive tape + 3 servo)

电源 Power	3P AC380V 50Hz 4.5/2.5/3.5kW
气源压力 (MPa) Air pressure	0.6-0.8
外形尺寸 (mm) Machine dimension	L2831×W2671×H1900 L4000×W1600×H2200 L3500×W1500×H2200
机器重量 (kg) Machine weight	2000
台面高度 (mm) Working table height	1000±50
胶带宽度 (mm) Tape width	48-72
工作速度 (boxes/min) Speed	20-40(50)



CF-20TN 纸箱成型机  
Carton erector

电源 Power	220V 50Hz 500W
气源压力 (MPa) Air pressure	0.6-0.8
外形尺寸 (mm) Machine dimension	3050*1950*1500
机器重量 (kg) Machine weight	700
胶带宽度 (mm) Tape width	48-72
工作速度 (boxes/min) Speed	12 (标准箱) (Standard box)
选配 (mm) Selection	平储料台 (3050*2650*1500) Storage platform



CF-40T-H 纸箱成型机 (双用+3个伺服)  
Carton erector (Double use +three servo)  
CF-40T-TH 纸箱成型机 (双用+2个伺服)  
Carton erector (Double use +two servo)

电源 Power	3P AC380V 50Hz 8/7kW
气源压力 (MPa) Air pressure	0.6-0.8
外形尺寸 (mm) Machine dimension	4800*2200*2200
机器重量 (kg) Machine weight	4000
台面高度 (mm) Working table height	1000±50
工作速度 (boxes/min) Speed	20-50 (标准箱) (Standard box)

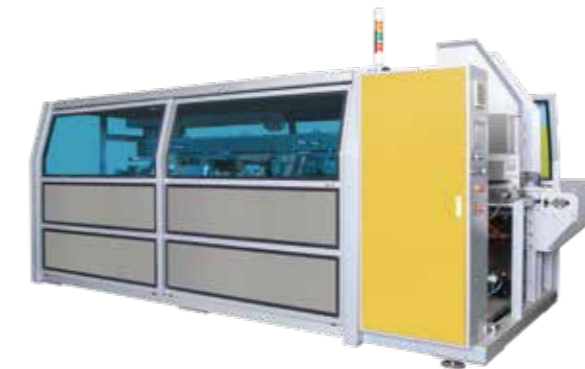



CF-25TB 机械手开箱  
One-click robot carton erector

电源 Power	1P 220V 50HZ 4.6KW
气源压力 (MPa) Air pressure	0.6-0.8
外形尺寸 (mm) Machine dimension	2710*2480*2180
机器重量 (kg) Machine weight	1000
胶带宽度 (mm) Tape width	48-72
工作速度 (boxes/min) Speed	20-30 (标准箱) (Standard box)

## CARTON PACKER 装箱机



CF-YS620 多工位机器人开箱机  
Robot carton erector

电源 Power	220V 50Hz 6.7KW
气源压力 (MPa) Air pressure	0.6-0.8
外形尺寸 (mm) Machine dimension	4050*2220*2400
胶带宽度 (mm) Tape width	48-72
工作速度 (boxes/min) Speed	依纸箱大小而定 (Based on box size)



平移式装箱机  
Translational carton packer

型号 Model	YS-CX-15T	YS-CX-30T	YS-CX-60T
电源 Power supply	AC380V 50Hz 7-10kW	AC380V 0Hz 10-12kW	AC380V 50Hz 12-15kW
压缩空气压力 (MPa) Air pressure	0.6-0.8	0.6-0.8	0.6-0.8
工作速度 (cases/min) Speed	12-15	20-30	40-55
抓头数量 (group) Carton Packer gripper	1-3	4-6	8-12
耗气量 (m <sup>3</sup> /h) Air consumption	20-40	30-40	30-60



YS-CX-L-10T 落差式装箱机  
Fall carton packer

电源 Power supply	AC380V 50Hz 3-6kW
压缩空气压力 (MPa) Air pressure	0.6-0.8
工作速度 (cases/min) Speed	6-14

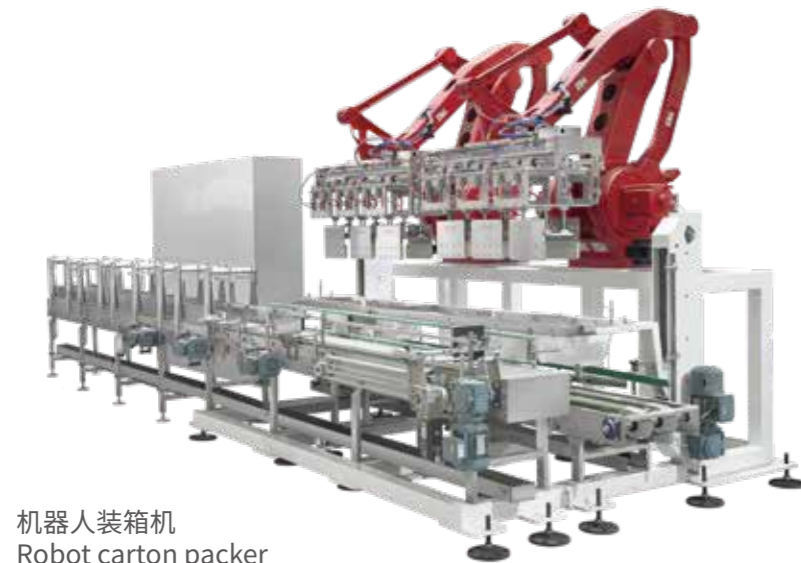

机器人装箱机  
Robot carton packer

型号 Model	YS-CX-15T	YS-CX-R-25T	YS-CX-R-35T	YS-CX-R-60T (双通道 Two lanes)	YS-CX-R-80T (双通道 Two lanes)
电源 Power supply	AC380V 50Hz 7-10kW	AC380V 50Hz 8-12kW	AC380V 50Hz 12-16kW	AC380V 50Hz 12-15kW	AC380V 50Hz 12-15kW
压缩空气压力 (MPa) Air pressure	0.6-0.8	0.6-0.8	0.6-0.8	0.6-0.8	0.6-0.8
工作速度 (cases/min) Speed	10-18	18-24	24-35	50-60	55-70
抓头数量 (group) Carton Packer gripper	1-3	3-4	4-6	8-1	12
耗气量 (m <sup>3</sup> /h) Air consumption	20-40	30-50	30-60	30-60	30-60



YS-CXF-K-10T 平移式开箱-装箱一体机  
Case Packing Line

电源 Power supply	AC380V 50Hz
压缩空气压力 (MPa) Air pressure	0.6-0.8
工作速度 (cases/min) Speed	10
适用产品 Applicable products	小盒装大箱或不规则产品等 Small boxes in large boxes, irregular products, etc.

YS-CXF-J-10T 平移式装箱机 (抓手)  
Translational carton packer (Gripper)



YS-CXF-Z-10T 蜘蛛手装箱机  
Delta robot carton packer

电源 Power supply	AC380V 50Hz 3-12kW
压缩空气压力 (MPa) Air pressure	0.6-0.8
工作速度 (cases/min) Speed	1-10
抓头数量 (group) Carton Packer gripper	1-3
耗气量 (m <sup>3</sup> /h) Air consumption	20-40

YS-CXF-Z-10TX 蛛手装箱机  
Delta robot carton packer

电源 Power supply	AC380V 50Hz 3-12kW
压缩空气压力 (MPa) Air pressure	0.6-0.8
工作速度 (cases/min) Speed	1-10
抓手数量 (group) Carton Packer gripper	1
耗气量 (m³/h) Air consumption	20-40



**LABELING MACHINE**  
**贴标机**



YSR-6-20-F/1600 协作机器人装箱机  
Robot carton packer

电源 Power supply	AC380V 50Hz
压缩空气压力 (MPa) Air pressure	0.6-0.8
工作速度 (cases/min) Speed	1-8
适用产品 Applicable products	小盒装大箱或不规则产品等 Small boxes in large boxes, irregular products, etc.



### YTB-A2000 全自动贴标机 Labeling machine

电源 Power supply	AC220V 50Hz 0.58kW
适用容器范围 (mm) Applicable container range	Φ(25-100), H(40-200) (可定制) (Customized)
标签尺寸范围 (mm) Label range	L(15-250)*H(20-120) (可定制) (Customized)
标签卷尺寸 (mm) Label scroll	内径Φ76, 外径Φ280 Inner dia Φ76, outer dia Φ280
贴标速度 (pcs/min) Labeling speed	0-25 (一张标签时, 速度大小取决于瓶子大小和标签长度) 0-15 (两张标签时, 两张标签的宽度尺寸应一样) (One label, depend on the bottle size and label length) (Two labels, the labels have the same width)
贴标精度 (mm) Labeling precision	±1(一张标签 One label); ±1.5(两张标签 Two labels)
机器尺寸 (mm) Machine dimension	1800*1100*1600



### YTB-B2000 全自动贴标机 Labeling machine

电源 Power supply	AC220V 50Hz 1.6kW
适用容器范围 (mm) Applicable container range	Φ(25-100), H(40-300) (可定制) (Customized)
标签尺寸范围 (mm) Label range	L(15-250)*H(20-120) (可定制) (Customized)
标签卷尺寸 (mm) Label scroll	内径Φ76, 外径Φ280 Inner dia Φ76, outer dia Φ280
贴标速度 (m/min) Labeling speed	25 (步进电机, 速度大小取决于标签长度) 40 (伺服电机, 速度大小取决于标签长度) (Step, depend on the label length) (Servo, depend on the label length)
贴标精度 (mm) Labeling precision	±1
机器尺寸 (mm) Machine dimension	2800*1600*1750



### YTB-AB2000 全自动贴标机 Labeling machine

电源 Power supply	AC220V 50Hz 0.67kW
适用容器范围 (mm) Applicable container range	Φ(25-100), H(50-300) (可定制) (Customized)
标签尺寸范围 (mm) Label range	L(15-250)*H(20-120) (可定制) (Customized)
标签卷尺寸 (mm) Label scroll	内径Φ76, 外径Φ280 Inner dia Φ76, outer dia Φ280
贴标速度 (m/min) Labeling speed	25 (步进电机, 速度大小取决于标签长度) 40 (伺服电机, 速度大小取决于标签长度) (Step, depend on the label length) (Servo, depend on the label length)
贴标精度 (mm) Labeling precision	±1
机器尺寸 (mm) Machine dimension	1800*1100*1600



### YTB-CA2000 全自动贴标机 Labeling machine

电源 Power supply	AC220V 50Hz 0.49kW
适用容器范围 (mm) Applicable container range	≤150 (可定制) (Customized)
标签尺寸范围 (mm) Label range	L(15-250)*H(20-120) (可定制) (Customized)
标签卷尺寸 (mm) Label scroll	内径Φ76, 外径Φ280 Inner dia Φ76, outer dia Φ280
贴标速度 (m/min) Labeling speed	25 (步进电机, 速度大小取决于标签长度) 40 (伺服电机, 速度大小取决于标签长度) (Step, depend on the label length) (Servo, depend on the label length)
贴标精度 (mm) Labeling precision	±2
机器尺寸 (mm) Machine dimension	1500*1000*1500



### YTB-AC2000 全自动贴标机 Labeling machine

电源 Power supply	AC220V 50Hz 0.83kW
适用容器范围 (mm) Applicable container range	Φ(10-20), H(25-95) (可定制) (Customized)
标签尺寸范围 (mm) Label range	L(25-75)*H(25-75) (可定制) (Customized)
标签卷尺寸 (mm) Label scroll	内径Φ76, 外径Φ280 Inner dia Φ76, outer dia Φ280
贴标速度 (pcs/min) Labeling speed	0-150 (步进电机, 速度大小取决于标签长度) 0-250 (伺服电机, 速度大小取决于标签长度) (Step, depend on the label length) (Servo, depend on the label length)
贴标精度 (mm) Labeling precision	±0.5
机器尺寸 (mm) Machine dimension	1830*700*1650



### YTB-CB2000 全自动贴标机 Labeling machine

电源 Power supply	AC220V 50Hz 0.49kW
适用容器范围 (mm) Applicable container range	≤150 (可定制) (Customized)
标签尺寸范围 (mm) Label range	L(15-250)*H(20-120) (可定制) (Customized)
标签卷尺寸 (mm) Label scroll	内径Φ76, 外径Φ280 Inner dia Φ76, outer dia Φ280
贴标速度 (m/min) Labeling speed	25 (步进电机, 速度大小取决于标签长度) 40 (伺服电机, 速度大小取决于标签长度) (Step, depend on the label length) (Servo, depend on the label length)
贴标精度 (mm) Labeling precision	±2
机器尺寸 (mm) Machine dimension	1500*1000*1500



### YTB-DB2000 全自动吸贴贴标机 Labeling machine

电源 Power supply	AC220V 50Hz 0.4kW
标签尺寸范围 (mm) Label range	L(30-150)*H(20-120) (可定制) (customized)
标签卷尺寸 (mm) Label scroll	内径Φ76, 外径Φ280 Inner dia Φ76, outer dia Φ280
贴标速度 (pcs/min) Labeling speed	0-10, 一张标签, 速度大小取决于方形物体的大小和标签长度 One label, depend on the object size and label length
贴标精度 (mm) Labeling precision	±3
机器尺寸 (mm) Machine dimension	1000×700×1100



### YTB-B76 半自动贴标机 Labeling machine(Semi-automatic)

电源 Power supply	AC220V 50Hz 0.4kW
适用容器范围 (mm) Applicable container range	Φ(45-110), H(40-350) (可定制) (Customized)
标签尺寸范围 (mm) Label range	L(15-250)*H(15-130) (可定制) (Customized)
标签卷尺寸 (mm) Label scroll	内径Φ76, 外径Φ220 Inner dia Φ76, outer dia Φ220
贴标速度 (pcs/min) Labeling speed	0-50
机器尺寸 (mm) Machine dimension	530*600*450



### YTB-DC2000 即时打印贴标机 Instant printing labeling machine

电源 Power supply	AC220V 50Hz 0.5kW
标签尺寸范围 (mm) Label range	L(50-150)*H(40-120) (可定制) (Customized)
标签卷尺寸 (mm) Label scroll	内径Φ76, 外径Φ200 Inner dia Φ76, outer dia Φ200
贴标速度 (pcs/min) Labeling speed	0-15, 一张标签, 速度大小取决于方形物体的大小和标签长度 One label, depend on the object size and label length
贴标精度 (mm) Labeling precision	±3
机器尺寸 (mm) Machine dimension	1000*800*1450



### YTB-DC2000-YSR 机器人贴标 Robot labeling machine

电源 Power supply	AC220V 50Hz 2.68kW
适用容器范围 (mm) Applicable container range	L400, W300, H300
标签尺寸范围 (mm) Label range	L(50-150)*H(40-160) (可定制) (Customized)
标签卷尺寸 (mm) Label scroll	内径Φ76, 外径Φ200 Inner dia Φ76, outer dia Φ200
贴标速度 (pcs/min) Labeling speed	5-8
机器尺寸 (mm) Machine dimension	1300*1300*1600



### YTB-B72 标签分配器 Label allotter

电源 Power supply	AC220V 50Hz 0.09kW
适合标签长度 (mm) Label length	110-200
适合标签宽度 (mm) Label width	25-150
标签内径 (mm) Label inner diameter	Φ76 或 Φ40 (订货前须说明) Φ76 or Φ40 (Note before ordering)
标签外径 (mm) Label outer diameter	< Φ220
机器尺寸 (mm) Machine dimension	530*600*450

# CARTON SEALER 封箱机

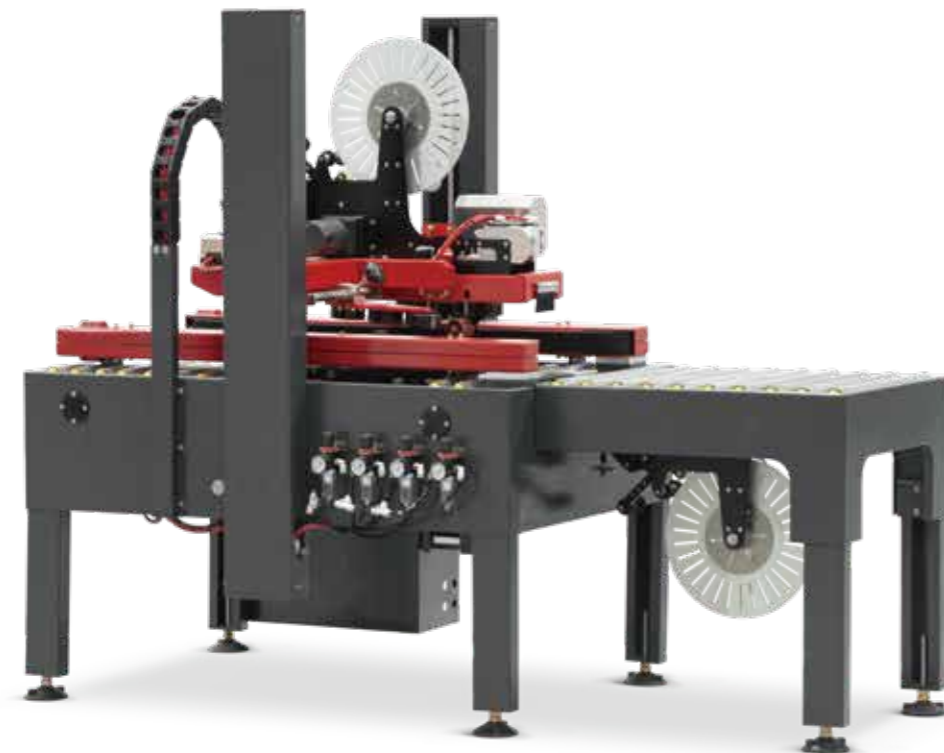

MH-FJ-1A 全自动封箱机  
Automatic carton sealer

电源 Power supply	AC220V 50Hz 0.6kW
封箱方式 Sealing mode	牛皮纸胶带、BOPP胶带 Kraft paper tape, BOPP tape
胶带宽度 (mm) Tape width	48-72
纸箱规格 (mm) Carton size	L150-∞, W120-480, H120-480
封箱速度 (m/min) Speed	20
工作台面高度 (mm) Table height	550-750 (脚杯 Foot cup) 650-850 (脚轮 Castor wheel)
外形尺寸 (mm) Overall dimension	1090*890*H(台面高度加750) Table height plus 750



MH-FJ-1AW 全自动封箱机  
Automatic carton sealer

电源 Power supply	AC220V 50Hz 0.4kW
封箱方式 Sealing mode	牛皮纸胶带、BOPP胶带 Kraft paper tape, BOPP tape
胶带宽度 (mm) Tape width	48-72
纸箱规格 (mm) Carton size	L150-∞, W120-480, H120-480
封箱速度 (m/min) Speed	20
工作台面高度 (mm) Table height	550-750 (脚杯 Foot cup) 650-850 (脚轮 Castor wheel)
外形尺寸 (mm) Overall dimension	1090*890*H(台面高度加750) Table height plus 750



MH-FJ-1AE 全自动封箱机  
Automatic carton sealer

电源 Power supply	AC380V 50Hz 0.6kW
封箱方式 Sealing mode	牛皮纸胶带、BOPP胶带 Kraft paper tape, BOPP tape
胶带宽度 (mm) Tape width	48-72
纸箱规格 (mm) Carton size	L150-∞, W120-480, H120-480
封箱速度 (m/min) Speed	20
工作台面高度 (mm) Table height	550-750 (脚杯 Foot cup) 650-850 (脚轮 Castor wheel)
外形尺寸 (mm) Overall dimension	1090*890*H(台面高度加750) Table height plus 750



### MH-FJ-1AWE 全自动封箱机 Automatic carton sealer

电源 Power supply	AC380V 50Hz 0.4kW
封箱方式 Sealing mode	牛皮纸胶带、BOPP胶带 Kraft paper tape, BOPP tape
胶带宽度 (mm) Tape width	48-72
纸箱规格 (mm) Carton size	L150-∞, W120-480, H120-480
封箱速度 (m/min) Speed	20
工作台面高度 (mm) Table height	550-750 (脚杯 Foot cup) 650-850 (脚轮 Castor wheel)
外形尺寸 (mm) Overall dimension	1090*890*H(台面高度加750) Table height plus 750



### MH-FJ-1S 全自动封箱机 Automatic carton sealer

电源 Power supply	AC220V 50Hz 0.4kW
封箱方式 Sealing mode	牛皮纸胶带、BOPP胶带 Kraft paper tape, BOPP tape
胶带宽度 (mm) Tape width	48-72
纸箱规格 (mm) Carton size	L150-∞, W190-440, H130-480
封箱速度 (m/min) Speed	20
工作台面高度 (mm) Table height	580-750 (脚杯 Foot cup) 680-880 (脚轮 Castor wheel)
外形尺寸 (mm) Overall dimension	960*890*H(台面高度加750) Table height plus 750



### MH-FJ-1AWS 全自动封箱机 Automatic carton sealer

电源 Power supply	AC220V 50Hz 0.4kW
封箱方式 Sealing mode	牛皮纸胶带、BOPP胶带 Kraft paper tape, BOPP tape
胶带宽度 (mm) Tape width	48
纸箱规格 (mm) Carton size	L180-∞, W95-300, H70-480
封箱速度 (m/min) Speed	20
工作台面高度 (mm) Table height	550-750 (脚杯 Foot cup) 630-820 (脚轮 Castor wheel)
外形尺寸 (mm) Overall dimension	1090*693*H(台面高度加750) Table height plus 750



### MH-FJ-2 气动封箱机 Pneumatic carton sealer

电源 Power supply	AC220V 50Hz 0.6kW
气源压力 (MPa) Air pressure	0.6-0.8
封箱方式 Sealing mode	牛皮纸胶带、BOPP胶带 Kraft paper tape, BOPP tape
胶带宽度 (mm) Tape width	48-72
纸箱规格 (mm) Carton size	L150-∞, W120-470, H120-450
封箱速度 (m/min) Speed	20
工作台面高度 (mm) Table height	550-750 (脚杯 Foot cup) 630-820 (脚轮 Castor wheel)
外形尺寸 (mm) Overall dimension	1154*890*H(台面高度加840) Table height plus 840



### MH-FJ-1D 全自动封箱机 Automatic carton sealer

电源 Power supply	AC220V 50Hz 0.4kW
封箱方式 Sealing mode	牛皮纸胶带、BOPP胶带 Kraft paper tape, BOPP tape
胶带宽度 (mm) Tape width	48-72
纸箱规格 (mm) Carton size	L150-∞, W180-620, H120-480
封箱速度 (m/min) Speed	20
工作台面高度 (mm) Table height	530-750 (脚杯 Foot cup) 630-830 (脚轮 Castor wheel)
外形尺寸 (mm) Overall dimension	970*890*H(台面高度加750) Table height plus 750



### MH-FJ-3A 自动折盖封箱机 With guard automatic carton sealer

电源 Power supply	AC220V 50Hz 0.4kW
气源压力 (MPa) Air pressure	0.6-0.8
封箱方式 Sealing mode	牛皮纸胶带、BOPP胶带 Kraft paper tape, BOPP tape
胶带宽度 (mm) Tape width	48-72
纸箱规格 (mm) Carton size	L200-550, W150-480, H120-480
封箱速度 (m/min) Speed	20
工作台面高度 (mm) Table height	550-750 (脚杯 Foot cup) 630-820 (脚轮 Castor wheel)
外形尺寸 (mm) Overall dimension	1650*890*H(台面高度加890) Table height plus 890



**MH-FJ-3AE 自动折盖封箱机**  
With guard automatic carton sealer

电源 Power supply	AC220V 50Hz 0.6kW
气源压力 (MPa) Air pressure	0.6-0.8
封箱方式 Sealing mode	牛皮纸胶带、BOPP胶带 Kraft paper tape, BOPP tape
胶带宽度 (mm) Tape width	48-72
纸箱规格 (mm) Carton size	L200-550, W150-480, H120-480
封箱速度 (m/min) Speed	20
工作台面高度 (mm) Table height	550-750 (脚杯 Foot cup) 650-800 (脚轮 Castor wheel)
外形尺寸 (mm) Overall dimension	1650*890*H(台面高度加890) Table height plus 890



**MH-FJ-3D 全自动封箱机**  
Automatic carton sealer

电源 Power supply	AC380V 50Hz 1.37kW
气源压力 (MPa) Air pressure	0.6-0.8
封箱方式 Sealing mode	牛皮纸胶带、BOPP胶带 Kraft paper tape, BOPP tape
胶带宽度 (mm) Tape width	48-72
纸箱规格 (mm) Carton size	L300-1400, W180-480, H160-480 (可定制 Customized)
封箱速度 (m/min) Speed	22
工作台面高度 (mm) Table height	550-750 (脚杯 Foot cup) 630-820 (脚轮 Castor wheel)
外形尺寸 (mm) Overall dimension	2500*990*H(台面高度加1100) Table height plus 1100



**MH-FJ-3AR 单通道封箱机**  
With guard automatic carton sealer

电源 Power supply	AC380V 50Hz 0.6kW
气源压力 (MPa) Air pressure	0.6-0.8
封箱方式 Sealing mode	牛皮纸胶带、BOPP胶带或热熔胶 Kraft paper tape, BOPP tape or Hot melt adhesive
胶带宽度 (mm) Tape width	48-72
纸箱规格 (mm) Carton size	L200-500, W150-480, H120-480
封箱速度 (cases/min) Speed	≤45
外形尺寸 (mm) Overall dimension	2100*900*H(台面高度加1000) Table height plus 1000

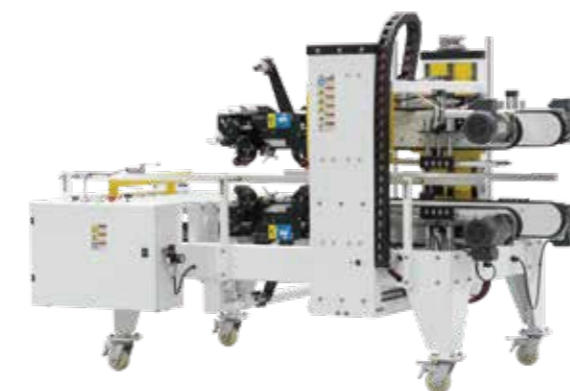

**MH-FJ-P1(ZP1) 角边式全自动封箱机**  
Corner-type automatic carton sealer

电源 Power supply	AC220V 50Hz 1.0kW
气源压力 (MPa) Air pressure	0.6-0.8
封箱方式 Sealing mode	牛皮纸胶带、BOPP胶带 Kraft paper tape, BOPP tape
胶带宽度 (mm) Tape width	48-72
纸箱规格 (mm) Carton size	L340-670, W200-480, H200-500
封箱速度 (m/min) Speed	20
工作台面高度 (mm) Table height	600-750 (可定制) (Customized)
外形尺寸 (mm) Overall dimension	2200*1240*H(2300*1240*H) (台面高度加800) Table height plus 800



**MH-FJ-3B 自动折盖封箱机**  
With guard automatic carton sealer

电源 Power supply	AC380V 50Hz 1.2kW
气源压力 (MPa) Air pressure	0.6-0.8
封箱方式 Sealing mode	牛皮纸胶带、BOPP胶带 Kraft paper tape, BOPP tape
胶带宽度 (mm) Tape width	48-72
纸箱规格 (mm) Carton size	L250-500, W200-450, H150-450
封箱速度 (m/min) Speed	27
工作台面高度 (mm) Table height	550-750 (脚杯 Foot cup)
外形尺寸 (mm) Overall dimension	2200*1100*H(台面高度加1400) Table height plus 1400



**YS-501AW 全自动封箱机**  
Automatic carton sealer

电源 Power supply	AC220V 50Hz 0.4kW
封箱方式 Sealing mode	牛皮纸胶带、BOPP胶带 Kraft paper tape, BOPP tape
胶带宽度 (mm) Tape width	48-72
纸箱规格 (mm) Carton size	L150-∞, W120-480, H120-480
封箱速度 (m/min) Speed	20
工作台面高度 (mm) Table height	610-750 (脚杯 Foot cup) 700-820 (脚轮 Castor wheel)
外形尺寸 (mm) Overall dimension	1090*890*H(台面高度加800) Table height plus 800



YS-501D 全自动封箱机  
Automatic carton sealer

电源 Power supply	AC220V 50Hz 0.4kW
封箱方式 Sealing mode	牛皮纸胶带、BOPP胶带 Kraft paper tape, BOPP tape
胶带宽度 (mm) Tape width	48-72
纸箱规格 (mm) Carton size	L150-∞, W180-550, H120-480
封箱速度 (m/min) Speed	20
工作台面高度 (mm) Table height	610-750 (脚杯foot cup) 700-820 (脚轮castor wheel)
外形尺寸 (mm) Overall dimension	970*890*H(台面高度加750) Table height plus 750



YS-502D 全自动封箱机  
Automatic carton sealer

电源 Power supply	AC220V 50Hz 0.4kW
气源压力 (MPa) Air pressure	0.6-0.8
封箱方式 Sealing mode	牛皮纸胶带、BOPP胶带 Kraft paper tape, BOPP tape
胶带宽度 (mm) Tape width	48-72
纸箱规格 (mm) Carton size	L150-∞, W180-550, H180-600
封箱速度 (m/min) Speed	22
工作台面高度 (mm) Table height	550-750 (脚杯 Foot cup) 630-800 (脚轮Castor wheel)
外形尺寸 (mm) Overall dimension	1970*910*H(台面高度加880) Table height plus 880



YS-501X 全自动封箱机  
Automatic carton sealer

电源 Power supply	AC220V 50Hz 0.4kW
封箱方式 Sealing mode	牛皮纸胶带、BOPP胶带 Kraft paper tape, BOPP tape
胶带宽度 (mm) Tape width	48-72
纸箱规格 (mm) Carton size	L150-∞, W180-550, H120-480
封箱速度 (m/min) Speed	20
工作台面高度 (mm) Table height	550-750 (脚杯foot cup) 660-800 (脚轮castor wheel)
外形尺寸 (mm) Overall dimension	1140*1010*H(台面高度加820) Table height plus 820



YS-601AW 全自动封箱机  
Automatic carton sealer

电源 Power supply	AC220V 50Hz 0.4kW
气源压力 (MPa) Air pressure	0.6-0.8
封箱方式 Sealing mode	牛皮纸胶带、BOPP胶带 Kraft paper tape, BOPP tape
胶带宽度 (mm) Tape width	48-72
纸箱规格 (mm) Carton size	L200-500, W150-400, H120-450
封箱速度 (m/min) Speed	22
工作台面高度 (mm) Table height	600-750 (脚杯 Foot cup) 730-850 (脚轮 Castor wheel)
外形尺寸 (mm) Overall dimension	1765*890*H(台面高度加700) Table height plus 700



YS-502 全自动封箱机  
Automatic carton sealer

电源 Power supply	AC220V 50Hz 0.4kW
气源压力 (MPa) Air pressure	0.6-0.8
封箱方式 Sealing mode	牛皮纸胶带、BOPP胶带 Kraft paper tape, BOPP tape
胶带宽度 (mm) Tape width	48-72
纸箱规格 (mm) Carton size	L150-∞, W120-480, H130-480
封箱速度 (m/min) Speed	20
工作台面高度 (mm) Table height	600-750 (脚杯 Foot cup) 700-820 (脚轮 Castor wheel)
外形尺寸 (mm) Overall dimension	1154*920*H(台面高度加750) Table height plus 750



MA 迷你封箱机  
Mini carton sealer

电源 Power supply	AC220V 50Hz 0.4kW
封箱方式 Sealing mode	牛皮纸胶带、BOPP胶带 Kraft paper tape, BOPP tape
胶带宽度 (mm) Tape width	48-60
纸箱规格 (mm) Carton size	L150-∞, W120-490, H120-490
封箱速度 (m/min) Speed	22
工作台面高度 (mm) Table height	600-700 (脚杯 Foot cup) 720-750 (脚轮 Castor wheel)
外形尺寸 (mm) Overall dimension	800*920*H(视封箱高度变化) H (According to sealing Height)



**MH-FJ-S3A 封箱机**  
Carton sealer

电源 Power supply	AC220V 50Hz 0.4kW
气源压力 (MPa) Air pressure	0.6-0.8
封箱方式 Sealing mode	牛皮纸胶带、BOPP胶带 Kraft paper tape, BOPP tape
胶带宽度 (mm) Tape width	48-72
纸箱规格 (mm) Carton size	L130-350, W80-190, H90-230
封箱速度 (m/min) Speed	20
工作台面高度 (mm) Table height	550-750 (脚杯 Foot cup) 630-820 (脚轮 Castor wheel)
外形尺寸 (mm) Overall dimension	1450*650*H(台面高度加650) Table height plus 650



**MH-FJ-SMA + MH-FJ-SMA-Z 十字封箱机**  
Cross carton sealer

电源 Power supply	AC220V 50Hz 0.4kW
气源压力 (MPa) Air pressure	0.6-0.8
封箱方式 Sealing mode	牛皮纸胶带、BOPP胶带 Kraft paper tape, BOPP tape
胶带宽度 (mm) Tape width	48-72
纸箱规格 (mm) Carton size	L200-500, W150-400, H120-450
封箱速度 (m/min) Speed	22
工作台面高度 (mm) Table height	600-750 (脚杯 Foot cup) 730-850 (脚轮 Castor wheel)
外形尺寸 (mm) Overall dimension	1765*890*H(台面高度加700) Table height plus 700

**STRAPPING MACHINE**  
**打包机**





### MH-101A 全自动捆扎机 (普通台面+高台) Automatic strapping machine

电源 Power supply	380V 50/60Hz 1.0kW
整机尺寸 (mm) Machine dimension	1400*628*1418
捆扎规格 (mm) Strapping specifications	最小包装尺寸: 宽100*高80 标准框架尺寸: 宽800*高600 (可定制) Minimum packing size: W100*H80 Standard frame size: W800*H600 (Customized)
工作台面高度 (mm) Working table height	750 (可定制) (Customized)
捆扎速度 (sec/cycle) Packing speed	≤2.5
捆扎带规格 (mm) PP strap	宽9-15(±1), 厚0.55-1.0(±0.1) Width 9-15(±1), thickness 0.55-1.0(±0.1)



### MH-103A 全自动捆扎机 Automatic strapping machine

电源 Power supply	380V 50/60Hz 1.0kW
整机尺寸 (mm) Machine dimension	1860*628*1350
捆扎规格 (mm) Strapping specifications	最小包装尺寸: 宽100*高80 标准框架尺寸: 宽600*高800 (可定制) Minimum packing size: W80*H100 Standard frame size: W600*H800 (Customized)
工作台面高度 (mm) Working table height	可定制 (Customized)
捆扎速度 (sec/cycle) Packing speed	≤2.5
捆扎带规格 (mm) PP strap	宽9-15(±1), 厚0.55-1.0(±0.1) Width 9-15(±1), thickness 0.55-1.0(±0.1)



### MH-101B 全自动捆扎机 (普通台面+低台) Automatic strapping machine

电源 Power supply	380V 50/60Hz 1.0kW
整机尺寸 (mm) Machine dimension	1905*628*1850
捆扎规格 (mm) Strapping specifications	最小包装尺寸: 宽100*高80 标准框架尺寸: 宽800*高600 (可定制) Minimum packing size: W100*H80 Standard frame size: W800*H600 (Customized)
工作台面高度 (mm) Working table height	450 (可定制) (Customized)
捆扎速度 (sec/cycle) Packing speed	≤2.5
捆扎带规格 (mm) PP strap	宽9-15(±1), 厚0.55-1.0(±0.1) Width 9-15(±1), thickness 0.55-1.0(±0.1)



### MH-103B 全自动捆扎机 Automatic strapping machine

电源 Power supply	380V 50/60Hz 1.0kW
整机尺寸 (mm) Machine dimension	1860*628*1350
捆扎规格 (mm) Strapping specifications	最小包装尺寸: 宽80*高100 标准框架尺寸: 宽600*高800 (可定制) Minimum packing size: W80*H100 Standard frame size: W600*H800 (Customized)
工作台面高度 (mm) Working table height	可定制 (Customized)
捆扎速度 (sec/cycle) Packing speed	≤2.5
捆扎带规格 (mm) PP strap	宽9-15(±1), 厚0.55-1.0(±0.1) Width 9-15(±1), thickness 0.55-1.0(±0.1)



### MH-102A 全自动捆扎机 (滚筒台面+高台) Automatic strapping machine

电源 Power supply	380V 50/60Hz 1.4kW
整机尺寸 (mm) Machine dimension	1580*650*1418
捆扎规格 (mm) Strapping specifications	最小包装尺寸: 宽210*高80 标准框架尺寸: 宽800*高600 (可定制) Minimum packing size: W210*H100 Standard frame size: W800*H600 (Customized)
工作台面高度 (mm) Working table height	750 (可定制) (Customized)
捆扎速度 (sec/cycle) Packing speed	≤2.5
捆扎带规格 (mm) PP strap	宽9-15(±1), 厚0.55-1.0(±0.1) Width 9-15(±1), thickness 0.55-1.0(±0.1)



### MH-102B 全自动捆扎机 (滚筒台面+低台) Automatic strapping machine

电源 Power supply	380V 50/60Hz 1.4kW
整机尺寸 (mm) Machine dimension	1905*628*1850
捆扎规格 (mm) Strapping specifications	最小包装尺寸: 宽100*高80 标准框架尺寸: 宽800*高600 (可定制) Minimum packing size: W100*H80 Standard frame size: W800*H600 (Customized)
工作台面高度 (mm) Working table height	450 (可定制) (Customized)
捆扎速度 (sec/cycle) Packing speed	≤2.5
捆扎带规格 (mm) PP strap	宽9-15(±1), 厚0.55-1.0(±0.1) Width 9-15(±1), thickness 0.55-1.0(±0.1)



MH-X202A 全自动捆扎机  
(滚筒台面, 高台)  
Automatic strapping machine

### MH-X201 全自动捆扎机 (普通台面, 高台) Automatic strapping machine

电源 Power supply	220V(380V) 50/60Hz 0.4kW(0.8kW)
整机尺寸 (mm) Machine dimension	1400*628*1435 (1440*650*1422)
捆扎规格 (mm) Strapping specifications	最小包装尺寸: 宽80*高60 (最小包装尺寸: 宽210*高80) 标准框架尺寸: 宽800*高600 (可定制) Minimum packing size: W80*H60 Standard frame size: W800*H600 (Customized)
工作台面高度 (mm) Working table height	750 (可定制) (Customized)
捆扎速度 (sec/cycle) Packing speed	≤2.5
捆扎带规格 (mm) PP strap	宽9-15(±1), 厚0.55-1.0(±0.1) Width 9-15(±1), thickness 0.55-1.0(±0.1)



### MH-X201B 全自动捆扎机 (普通台面, 低台) Automatic strapping machine

电源 Power supply	220V(380V) 50/60Hz 0.4kW(0.8kW)
整机尺寸 (mm) Machine dimension	1810*628*1617 (1810*650*1617)
捆扎规格 (mm) Strapping specifications	最小包装尺寸: 宽80*高60 (最小包装尺寸: 宽210*高80) 标准框架尺寸: 宽800*高600 (可定制) Minimum packing size: W80*H60 Standard frame size: W800*H600 (Customized)
工作台面高度 (mm) Working table height	450 (可定制) 450 (Customized)
捆扎速度 (sec/cycle) Packing speed	≤2.5
捆扎带规格 (mm) PP strap	宽9-15(±1), 厚0.55-1.0(±0.1) Width 9-15(±1), thickness 0.55-1.0(±0.1)



### MH-301B 全自动捆扎机 (普通台面, 低台) Automatic strapping machine

电源 Power supply	220V 50/60Hz 0.5kW
整机尺寸 (mm) Machine dimension	1810*628*1617
捆扎规格 (mm) Strapping specifications	最小包装尺寸: 宽80*高60 标准框架尺寸: 宽800*高600 (可定制) Minimum packing size: W80*H60 Standard frame size: W800*H600 (Customized)
工作台面高度 (mm) Working table height	450 (可定制) (Customized)
捆扎速度 (sec/cycle) Packing speed	≤2.0
捆扎带规格 (mm) PP strap	宽9-15 (±1), 厚0.55-1.0(±0.1) Width 9-15 (±1), thickness 0.55-1.0 (±0.1)



### MH-301A 全自动捆扎机 (普通台面, 高台) Automatic strapping machine

电源 Power supply	220V 50/60Hz 0.5kW
整机尺寸 (mm) Machine dimension	1400*628*1435
捆扎规格 (mm) Strapping specifications	最小包装尺寸: 宽80*高60 标准框架尺寸: 宽800*高600 (可定制) Minimum packing size: W80*H60 Standard frame size: W800*H600 (Customized)
工作台面高度 (mm) Working table height	750 (可定制) (Customized)
捆扎速度 (sec/cycle) Packing speed	≤2.0
捆扎带规格 (mm) PP strap	宽9-15(±1), 厚0.55-1.0(±0.1) Width 9-15(±1), thickness 0.55-1.0(±0.1)



### MH-302B 全自动捆扎机 (滚筒台面, 低台) Automatic strapping machine

电源 Power supply	380V 50/60Hz 0.9kW
整机尺寸 (mm) Machine dimension	1810*650*1617
捆扎规格 (mm) Strapping specifications	最小包装尺寸: 宽210*高80 标准框架尺寸: 宽800*高600 (可定制) Minimum packing size: W80*H60 Standard frame size: W800*H600 (Customized)
工作台面高度 (mm) Working table height	450 (可定制) (Customized)
捆扎速度 (sec/cycle) Packing speed	≤2.0
捆扎带规格 (mm) PP strap	宽9-15 (±1), 厚0.55-1.0 (±0.1) Width 9-15 (±1), thickness 0.55-1.0 (±0.1)



### MH-302A 全自动捆扎机 (滚筒台面, 高台) Automatic strapping machine

电源 Power supply	380V 50/60Hz 0.9kW
整机尺寸 (mm) Machine dimension	1440*650*1422
捆扎规格 (mm) Strapping specifications	最小包装尺寸: 宽210*高80 标准框架尺寸: 宽800*高600 (可定制) Minimum packing size: W80*H60 Standard frame size: W800*H600 (Customized)
工作台面高度 (mm) Working table height	750 (可定制) (Customized)
捆扎速度 (sec/cycle) Packing speed	≤2.0
捆扎带规格 (mm) PP strap	宽9-15(±1), 厚0.55-1.0 (±0.1) Width 9-15(±1), thickness 0.55-1.0 (±0.1)



### MH-105A 全自动水平式捆扎机 Automatic horizontal strapping machine

电源 Power supply	380V 50/60Hz 3.1kW
气源压力 (MPa) Air pressure	0.6-0.8
整机尺寸 (mm) Machine dimension	1930*3240*2800
框架尺寸 (mm) Frame size	W1500*H1500 (可定制) (Customized)
捆扎速度 (sec/cycle) Packing speed	≤15
捆扎带规格 (mm) PP strap	宽9-15(±1), 厚0.55-1.0(±0.1) Width 9-15(±1), thickness 0.55-1.0(±0.1)
带盘规格 (mm) PP strap spool	宽160-180, 内径200-210, 外径400-500 W160-180, inner dia.200-210, outer dia.400-500



MH-105B 全自动穿剑式捆扎机  
Automatic vertical strapping machine

电源 Power supply	380V 50/60Hz 1.6kW
压缩空气压力 (MPa) Air pressure	0.6-0.8
整机尺寸 (mm) Machine dimension	4145*845*2630
框架尺寸 (mm) Frame size	W1500*H2000 (可定制) (Customized)
捆扎速度 (sec/cycle) Packing speed	≤15
捆扎带规格 (mm) PP strap	宽9-15(±0.1), 厚0.55-1.0(±0.1) Width 9-15(±0.1), thickness 0.55-1.0 (±0.1)
带盘规格 (mm) PP strap spool	宽160-180, 内径200-210, 外径400-500 W160-180, inner dia.200-210, outer dia.400-500



MH-105C 全自动顶压穿剑式捆扎机  
Automatic vertical strapping machine with top presser

电源 Power supply	380V 50/60Hz 4.0kW
整机尺寸 (mm) Machine dimension	4250*800*3300
框架尺寸 (mm) Frame size	W1500*H1800 (可定制) (Customized)
捆扎速度 (sec/cycle) Packing speed	≤15
捆扎带规格 (mm) PP strap	宽9-19(±0.1), 厚0.55-1.0(±0.1) Width 9-19(±0.1), thickness 0.55-1.0(±0.1)
带盘规格 (mm) PP strap spool	宽160-180, 内径200-210, 外径400-500 W160-180, inner dia.200-210, outer dia.400-500



YS-305 全自动捆扎机  
Automatic strapping machine

电源 Power supply	220V 50/60Hz 0.6kW
整机尺寸 (mm) Machine dimension	1180*585*1450
捆扎规格 (mm) Strapping specifications	最小包装尺寸: 宽80*高60 标准框架尺寸: 宽650*高500 (可定制) Minimum packing size: W80*H60 Standard frame size: W650*H500 (Customized)
工作台面高度 (mm) Working table height	850 (可定制) (Customized)
捆扎速度 (cycles/min) Packing speed	≤60
捆扎带规格 (mm) PP strap	宽5/6, 厚0.5-0.8, 内径200-210 Width 5/6, thickness 0.5-0.8, inner dia.200-210



YS-305X 全自动捆扎机  
Automatic strapping machine

电源 Power supply	220V 50/60Hz 0.9kW
整机尺寸 (mm) Machine dimension	1148*620*1465
捆扎规格 (mm) Strapping specifications	最小包装尺寸: 宽80*高60 标准框架尺寸: 宽650*高500 (可定制) Minimum packing size: W80*H60 Standard frame size: W650*H500(Customized)
工作台面高度 (mm) Working table height	850 (可定制) (Customized)
捆扎速度 (cycles/min) Packing speed	≤70
捆扎带规格 (mm) PP strap	宽5/6, 厚0.5-0.8 Width 8/9, thickness 0.5-0.8



YS-309 全自动捆扎机  
Automatic strapping machine

电源 Power supply	220V 50/60Hz 0.6kW
整机尺寸 (mm) Machine dimension	1180*585*1450
捆扎规格 (mm) Strapping specifications	最小包装尺寸: 宽80*高60 标准框架尺寸: 宽650*高500 (可定制) Minimum packing size: W80*H60 Standard frame size: W650*H500(Customized)
工作台面高度 (mm) Working table height	850 (可定制) (Customized)
捆扎速度 (cycles/min) Packing speed	≤60
捆扎带规格 (mm) PP strap	宽8/9, 厚0.5-0.8 Width 8/9, thickness 0.5-0.8



YS-305P 全自动捆扎机 (加压机)  
Automatic strapping machine

电源 Power supply	220V 50/60Hz 0.6kW
气源压力 (MPa) Air pressure	0.6-0.8
整机尺寸 (mm) Machine dimension	1510*585*1970
捆扎规格 (mm) Strapping specifications	最小包装尺寸: 宽80*高60 标准框架尺寸: 宽1250*高500 (可定制) Minimum packing size: W80*H60 Standard frame size: W1250*H500 (Customized)
工作台面高度 (mm) Working table height	850 (可定制) (Customized)
捆扎速度 (cycles/min) Packing speed	≤60
捆扎带规格 (mm) PP strap	宽5/6, 厚0.5-0.8 Width 5/6, thickness 0.5-0.8



YS-312 全自动捆扎机  
Automatic strapping machine

电源 Power supply	220V 50/60Hz 0.6kW
整机尺寸 (mm) Machine dimension	1180*585*1420
捆扎规格 (mm) Strapping specifications	最小包装尺寸: 宽80*高60 标准框架尺寸: 宽650*高500 (可定制) Minimum packing size: W80*H60 Standard frame size: W650*H500 (Customized)
工作台面高度 (mm) Working table height	850 (可定制) (Customized)
捆扎速度 (cycles/min) Packing speed	≤60
捆扎带规格 (mm) PP strap	宽11/12, 厚0.5-0.8 Width 11/12, thickness 0.5-0.8



YS-305B 全自动捆扎机 (台面皮带)  
Automatic strapping machine

电源 Power supply	220V 50/60Hz 1.0kW
整机尺寸 (mm) Machine dimension	L1480×W730×H1480
捆扎规格 (mm) Strapping specifications	最小包装尺寸: 宽150*高60 标准框架尺寸: 宽650*高500 (可定制) Minimum packing size: W150*H60 Standard frame size: W650*H500 (Customized)
工作台面高度 (mm) Working table height	850 (可定制) (Customized)
捆扎速度 (cycles/min) Packing speed	≤40
捆扎带规格 (mm) PP strap	宽5/6, 厚0.5-0.8 Width 5/6, thickness 0.5-0.8



YS-511-5 全自动捆扎机  
Automatic strapping machine

电源 Power supply	220V 50/60Hz 0.6kW
整机尺寸 (mm) Machine dimension	1180*585*1450
捆扎规格 (mm) Strapping specifications	最小包装尺寸: 宽80*高60 标准框架尺寸: 宽650*高500 (可定制) Minimum packing size: W80*H60 Standard frame size: W650*H500 (Customized)
工作台面高度 (mm) Working table height	850 (可定制) (Customized)
捆扎速度 (cycles/min) Packing speed	≤60
捆扎带规格 (mm) PP strap	宽5/6, 厚0.5-0.8 Width 5/6, thickness 0.5-0.8



YS-305BP 全自动捆扎机 (台面皮带+加压)  
Automatic strapping machine

电源 Power supply	220V 50/60Hz 1.0kW
气源压力 (MPa) Air pressure	0.6-0.8
整机尺寸 (mm) Machine dimension	1480*730*1980
捆扎规格 (mm) Strapping specifications	最小包装尺寸: 宽150*高60 标准框架尺寸: 宽650*高500 (可定制) Minimum packing size: W150*H60 Standard frame size: W650*H500 (Customized)
工作台面高度 (mm) Working table height	850 (可定制) (Customized)
捆扎速度 (cycles/min) Packing speed	≤40
捆扎带规格 (mm) PP strap	宽5/6, 厚0.5-0.8 Width 5/6, thickness 0.5-0.8



YS-511-12 全自动捆扎机  
Automatic strapping machine

电源 Power supply	220V 50/60Hz 0.6kW
整机尺寸 (mm) Machine dimension	1510*585*1970
捆扎规格 (mm) Strapping specifications	最小包装尺寸: 宽80*高60 标准框架尺寸: 宽1250*高500 (可定制) Minimum packing size: W80*H60 Standard frame size: W1250*H500 (Customized)
工作台面高度 (mm) Working table height	850 (可定制) (Customized)
捆扎速度 (cycles/min) Packing speed	≤60
捆扎带规格 (mm) PP strap	宽11/12, 厚0.5-0.8 Width 11/12, thickness 0.5-0.8



YS-305R 全自动捆扎机 (台面滚筒)  
Automatic strapping machine

电源 Power supply	220V 50/60Hz 1.0kW
整机尺寸 (mm) Machine dimension	1520*680*1500
捆扎规格 (mm) Strapping specifications	最小包装尺寸: 宽200*高60 标准框架尺寸: 宽1250*高500 (可定制) Minimum packing size: W200*H60 Standard frame size: W1250*H500 (Customized)
工作台面高度 (mm) Working table height	850 (可定制) (Customized)
捆扎速度 (cycles/min) Packing speed	≤30
捆扎带规格 (mm) PP strap	宽5/6, 厚0.5-0.8 Width 5/6, thickness 0.5-0.8



YS-305RP 全自动捆扎机 (台面滚筒+加压)  
Automatic strapping machine

电源 Power supply	220V 50/60Hz 1.0kW
气源压力 (MPa) Air pressure	0.6-0.8
整机尺寸 (mm) Machine dimension	1520*680*2000
捆扎规格 (mm) Strapping specifications	最小包装尺寸: 宽200*高60 标准框架尺寸: 宽1250*高50 (可定制) Minimum packing size: W200*H60 Standard frame size: W1250*H500 (Customized)
工作台面高度 (mm) Working table height	850 (可定制) (Customized)
捆扎速度 (cycles/min) Packing speed	≤30
捆扎带规格 (mm) PP strap	宽5/6, 厚0.5-0.8 Width 5/6, thickness 0.5-0.8



YS-405B 全自动捆扎机 (台面皮带+高台)  
Automatic strapping machine

电源 Power supply	220V 50/60Hz 1.0kW
整机尺寸 (mm) Machine dimension	1480*730*1480
捆扎规格 (mm) Strapping specifications	最小包装尺寸: 宽150*高60 标准框架尺寸: 宽650*高500 (可定制) Minimum packing size: W150*H60 Standard frame size: W650*H500 (Customized)
工作台面高度 (mm) Working table height	850 (可定制) (Customized)
捆扎速度 (cycles/min) Packing speed	≤55
捆扎带规格 (mm) PP strap	宽5/6, 厚0.5-0.8 Width 5/6, thickness 0.5-0.8



YS-305RPD全自动捆扎机 (台面滚筒+加压+双机芯)  
Automatic strapping machine

电源 Power supply	220V 50/60Hz 2.4kW
气源压力 (MPa) Air pressure	0.6-0.8
整机尺寸 (mm) Machine dimension	2120*1300*2100
捆扎规格 (mm) Strapping specifications	最小包装尺寸: 宽400*高60 标准框架尺寸: 宽1250*高500 (可定制) Minimum packing size: W400*H60 Standard frame size: W1250*H500 (Customized)
工作台面高度 (mm) Working table height	920 (可定制) (Customized)
捆扎速度 (packs/min) Packing speed	≤16
捆扎带规格 (mm) PP strap	宽5/6, 厚0.5-0.8 Width 5/6, thickness 0.5-0.8



YS-405BL 全自动捆扎机 (台面皮带+低台)  
Automatic strapping machine

电源 Power supply	220V 50/60Hz 1.0kW
整机尺寸 (mm) Machine dimension	1920*730*1600
捆扎规格 (mm) Strapping specifications	最小包装尺寸: 宽150*高60 标准框架尺寸: 宽650*高500 (可定制) Minimum packing size: W150*H60 Standard frame size: W650*H500 (Customized)
工作台面高度 (mm) Working table height	550 (可定制) (Customized)
捆扎速度 (cycles/min) Packing speed	≤55
捆扎带规格 (mm) PP strap	宽5/6, 厚0.5-0.8 Width 5/6, thickness 0.5-0.8



YS-405 全自动捆扎机  
Automatic strapping machine

电源 Power supply	220V 50/60Hz 0.6kW
整机尺寸 (mm) Machine dimension	1180*585*1450
捆扎规格 (mm) Strapping specifications	最小包装尺寸: 宽80*高60 标准框架尺寸: 宽650*高500 (可定制) Minimum packing size: W80*H60 Standard frame size: W650*H500 (Customized)
工作台面高度 (mm) Working table height	850 (可定制) (Customized)
捆扎速度 (cycles/min) Packing speed	≤60
捆扎带规格 (mm) PP strap	宽5/6, 厚0.5-0.8 Width 5/6, thickness 0.5-0.8



YS-405BD 全自动捆扎机 (台面皮带+双带盘)  
Automatic strapping machine

电源 Power supply	220V 50/60Hz 1.0kW
整机尺寸 (mm) Machine dimension	1720*730*1480
捆扎规格 (mm) Strapping specifications	最小包装尺寸: 宽150*高60 标准框架尺寸: 宽650*高500 (可定制) Minimum packing size: W150*H60 Standard frame size: W650*H500 (Customized)
工作台面高度 (mm) Working table height	850 (可定制) (Customized)
捆扎速度 (cycles/min) Packing speed	≤55
捆扎带规格 (mm) PP strap	宽5/6, 厚0.5-0.8 Width 5/6, thickness 0.5-0.8



YS-LX-500 全自动拢箱装置  
Automatic corrugated bundle squaring device

电源 Power supply	380V 50/60Hz 1.0kW
气源压力 (MPa) Air pressure	0.6-0.8
整机尺寸 (mm) Machine dimension	1900*2050*1470
工作台面高度 (mm) Working table height	850 (可定制) (Customized)
承重能力 (kg) Load capacity	80
捆扎速度 (packs/min) Packing speed	≤16
捆扎带规格 (mm) PP strap	L(250-1100)*W(320-1200)*H(0-450)



YS-LX-500D 全自动拢箱装置 (双工位)  
Automatic corrugated bundle squaring device (Double)

电源 Power supply	380V 50/60Hz 1.6kW
气源压力 (MPa) Air pressure	0.6-0.8
整机尺寸 (mm) Machine dimension	4650*1720*1300
工作台面高度 (mm) Working table height	850-950
承重能力 (kg) Load capacity	80
捆扎速度 (packs/min) Packing speed	≤20
捆扎带规格 (mm) PP strap	L(350-1100)*W(350-1100)*H(0-450)



YS-SZ90 全自动捆扎机 (报刊)  
Automatic strapping machine

电源 Power supply	380V 50/60Hz 3.0kW
整机尺寸 (mm) Machine dimension	2300*1480*1700
捆扎规格 (mm) Strapping specifications	最小包装尺寸: 宽150*高60 标准框架尺寸: 宽650*高500 (可定制) Minimum packing size: W150*H60 Standard frame size: W650*H500 (Customized)
工作台面高度 (mm) Working table height	850 (可定制) (Customized)
捆扎速度 (packs/min) Packing speed	≤20
捆扎带规格 (mm) PP strap	宽5-9, 厚0.5-0.8 Width 5-9, thickness 0.5-0.8



YS-A2F 半自动捆扎机 (高台四腿型)  
Semi-automatic strapping machine

电源 Power	AC220V 50/60Hz 0.25kW
捆扎速度 (cycles/min) Packing speed	≤20
捆紧力 (kg) Tension range	3-45
工作台面高度 (mm) Working table height	750
捆扎带规格 (mm) PP strap	聚丙烯, 宽5-15, 厚0.5-0.8 Width 5-15, thickness 0.5-0.8
带盘规格 (mm) PP strap spool	宽160-190, 内径200-210, 外径400-450 W160-190, inner dia.200-210, outer dia.400-450
整机尺寸 (mm) Machine dimension	840*540*750



YS-A2L 半自动捆扎机 (低台型)  
Semi-automatic strapping machine

电源 Power	AC220V 50/60Hz 0.25kW
捆扎速度 (cycles/min) Packing speed	≤20
捆紧力 (kg) Tension range	3-45
工作台面高度 (mm) Working table height	450
捆扎带规格 (mm) PP strap	聚丙烯, 宽5-15, 厚0.5-0.8 Width 5-15, thickness 0.5-0.8
带盘规格 (mm) PP strap spool	宽160-190, 内径200-210, 外径400-450 W160-190, inner dia.200-210, outer dia.400-450
整机尺寸 (mm) Machine dimension	750*550*450



AS-10F 半自动捆扎机 (高台四腿型)  
Semi-automatic strapping machine

电源 Power	AC220V 50/60Hz 0.25kW
捆扎速度 (cycles/min) Packing speed	≤20
捆紧力 (kg) Tension range	5-50
工作台面高度 (mm) Working table height	730
捆扎带规格 (mm) PP strap	聚丙烯, 宽5-15, 厚0.5-0.8 Width 5-15, thickness 0.5-0.8
带盘规格 (mm) PP strap spool	宽160-190, 内径200-210, 外径400-500 W160-190, inner dia.200-210, outer dia.400-500
整机尺寸 (mm) Machine dimension	850*550*730



### AS-10L 半自动捆扎机 (低台型) Semi-automatic strapping machine

电源 Power	AC220V 50/60Hz 0.25kW
捆扎速度 (cycles/min) Packing speed	≤20
捆紧力 (kg) Tension range	5-50
工作台面高度 (mm) Working table height	460
捆扎带规格 (mm) PP strap	聚丙烯, 宽5-15, 厚0.5-0.8 Width 5-15, thickness 0.5-0.8
带盘规格 (mm) PP strap spool	宽160-190, 内径200-210, 外径400-500 W160-190, inner dia.200-210, outer dia.400-500
整机尺寸 (mm) Machine dimension	850*545*460

### YB19/25 手持式气动PET带打包机 Pneumatic plastic strapping tools

用包装带尺寸 (mm) Apply straps size	带宽13-19/19-25, 带厚0.5-1.2/0.5-1.5 Width 13-19/19-25, thickness 0.5-1.2/0.5-1.5
适用打包带 Apply straps	PP/PET
进带模式 Forward mode	免分带 Free separate strap
封带形式 Seal straps form	摩擦热熔接 Friction and hot welding
最大束紧力 (N) Maximum tension force	3500
气源压力 (MPa) Air pressure	0.6-0.8
机器重量 (kg) Machine weight	3.8
机器规格 (mm) Specification	280*160*180

### Q2 手持式电动打包机 Battery powered strapping tool

用包装带尺寸 (mm) Apply straps size	带宽13-16, 带厚0.5-1.0 Width 13-16, thickness 0.5-1.0
适用打包带 Apply straps	PP/PET
电池规格 Battery specifications	5.0Ah 110V/220V
充电时间 (min) Charging time	90
打带数量 (pcs) Number of bands	700
机器拉力 (N) Pull	600-4000
拉紧速度 (cm/s) Tightening speed	18
熔接时间 (s) Splicing time	1.0-1.5 (可调) Adjustable
冷却时间 (s) Cooling time	2.5 (可调) Adjustable
机器重量 (kg) Machine weight	3.7
机器规格 (mm) Specification	370*150*140
工作模式 Operating mode	全自动、半自动、手动 Full automatic, semi-automatic, manual



### YS-T45 半自动捆扎机 (托盘式) Semi-automatic strapping machine (Pallet type)

电源 Power	AC220V 50/60Hz 0.25kW
捆扎速度 (cycles/min) Packing speed	≤20
捆紧力 (kg) Tension range	3-45
捆扎带规格 (mm) PP strap	聚丙烯, 宽9-15, 厚0.5-0.8 Width 9-15, thickness 0.5-0.8
带盘规格 (mm) PP strap spool	宽160-190, 内径200-210, 外径400-500 W160-190, inner dia.200-210, outer dia.400-500
整机尺寸 (mm) Machine dimension	770*580*850
机器重量 (kg) Machine weight	78



### YS-T150 半自动捆扎机 (托盘式) Semi-automatic strapping machine (Pallet type)

电源 Power	AC220V 50/60Hz 0.60kW
捆扎速度 (cycles/min) Packing speed	≤20
捆紧力 (kg) Tension range	5-150
捆扎带规格 (mm) PP strap	聚丙烯/PET, 宽9-15, 厚0.5-1.0 PP/PET width 9-15, thickness 0.5-1.0
带盘规格 (mm) PP strap spool	宽160-190, PET带卷内径406, 外径600 聚丙烯内径200-210, 外径400-500
整机尺寸 (mm) Machine dimension	W160-190, PET inner dia. 406, outer dia. 600, 1073*550*1670
机器重量 (kg) Machine weight	140

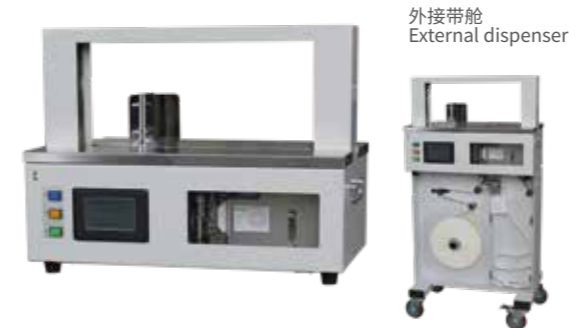

### AG02 束带机 Automatic banding machine

电源 Power	AC220V 50/60Hz 0.25kW
捆扎速度 (cycles/min) Packing speed	≤26
捆紧力 (kg) Tension range	≤5 (可调) (adjustable)
捆扎带规格 (mm) PP strap	纸/OPP薄膜带, 宽度为30 (20可选) Paper/OPP, width 30 (20 optional)
带盘规格 (mm) PP strap spool	带卷纸芯内径40, 外径180, 宽度20/30 OPP薄膜带内径42, 外径160, 宽度20/30 Width 20/30, paper inner dia. 40, outer dia. 180 OPP inner dia. 42, outer dia. 160
整机尺寸 (mm) Machine dimension	650*360*480 (650*360*1140)
机器重量 (kg) Machine weight	40 (75)



### AG03 束带机 Automatic banding machine

电源 Power	AC220V 50/60Hz 0.25kW
捆扎速度 (cycles/min) Packing speed	≤26
捆紧力 (kg) Tension range	≤5 (可调) (adjustable)
捆扎带规格 (mm) PP strap	OPP薄膜带, 宽度为12 OPP, width 12
带盘规格 (mm) PP strap spool	OPP薄膜带内径40, 外径160, 宽度12 Width 12, inner dia. 40, outer dia. 160
整机尺寸 (mm) Machine dimension	380*280*415 (520*280*505)
机器重量 (kg) Machine weight	18 (22)

# WRAPPING MACHINE 缠绕机



MH-FG-1000A 转盘式拉伸薄膜缠绕机  
Mechanical stretch automatic pallet stretch wrapper

电源 Power	3P AC380V 50 Hz / 1P AC 220V 50Hz
转盘速度 (rpm) Speed of turntable	0-10
转盘直径 (mm) Dia. of turntable	Φ1500
立柱高度 (mm) Mast height	2400
承重 (kg) Capacity	1500
有效高度 (mm) Effective height	2000
包装材料 (mm) Packaging material	宽≤500, 外直径≤Φ280 LLDPE 拉伸薄膜 W≤500, outer dia.≤Φ280 LLDPE film
机器尺寸 (mm) Machine dimension	1500*2440*2475

MH-FG-2000 转盘式拉伸薄膜缠绕机  
Pre-stretch automatic pallet stretch wrapper

电源 Power	1P AC220V 50Hz
转盘速度 (rpm) Speed of turntable	0-10
转盘直径 (mm) Dia. of turntable	Φ1500 (可选Φ1650/1800/2000/2200) (Optional Φ1650/1800/2000/2200)
立柱高度 (mm) Mast height	2400 (可选2000/2700/3000/3200/3400) (Optional 2000/2700/3000/3200/3400)
承重 (kg) Capacity	2000
有效高度 (mm) Effective height	立柱高度减400 Mast height minus 400
包装材料 (mm) Packaging material	宽≤500, 外直径≤Φ280 LLDPE 拉伸薄膜 W≤500, outer dia.≤Φ280 LLDPE film
机器尺寸 (mm) Machine dimension	1500*2440*2475

MH-FG-2000W 马蹄形转盘式拉伸薄膜缠绕机  
Automatic pallet stretch wrapper (Horseshoe shaped)

电源 Power	1P AC220V 50Hz
转盘速度 (rpm) Speed of turntable	0-10
转盘直径 (mm) Dia. of turntable	Φ1500 (可选 Φ1650) (Optional Φ1650)
叉车外宽 (mm) Forklift outer width	≤600
叉口方向 Direction	180°
承重 (kg) Capacity	1000
立柱高度 (mm) Mast height	2400 (可选 2000/2700/3000/3200/3400) (Optional 2000/2700/3000/3200/3400)
有效高度 (mm) Effective height	立柱高度减400 Mast height minus 400
包装材料 (mm) Packaging material	宽≤500, 外直径≤Φ280 LLDPE 拉伸薄膜 W≤500, outer dia.≤Φ280 LLDPE film
压顶行程 (mm) Working height	500 - 立柱高度减400 500 - mast height minus 400



### MH-FG-2000F 带上断膜转盘式拉伸薄膜缠绕机 Automatic pallet stretch wrapper

电源 Power	1P AC220/110V 50/60Hz
气源压力 (MPa) Air pressure	0.6-0.8
转盘速度 (rpm) Speed of turntable	0-10
转盘直径 (mm) Dia. of turntable	Φ1650 (可选 Φ1800/2000) (Optional Φ1800/2000)
立柱高度 (mm) Mast height	2400 (可选) (Optional 2700/3000/3200/3400)
承重 (kg) Capacity	2000
有效高度 (mm) Effective height	立柱高度减400 Mast height minus 400
包装材料 (mm) Packaging material	宽≤500, 外直径≤Φ280 LLDPE 拉伸薄膜 W≤500, outer dia.≤Φ280 LLDPE film



### CTV-200BD 环形缠绕机 Ring stretch wrapping machine

电源 Power	220V/240V/380V 50Hz
气源 (bar) Air source	6
耗气量 (ml/min) Air consumption	1000
转盘速度 (rpm) Speed of turntable	50
产能 (tray/h) Capacity	60
膜高 (mm) Film height	500
膜最大直径 (mm) Maximum dia. of film	Φ250
栈板尺寸 (mm) Mast height	最大 Maximum 1100*1300(高 H1000-2000) 最小 Minimum 500*600(高 H500-2000)
机器尺寸 (mm) Working height	2400*3100*4315



### MH-FG-2000C1/2000C3 带压顶机构拉伸薄膜缠绕机 With top-presser automatic pallet stretch wrapper

电源 Power	1P AC220V 50Hz
转盘速度 (rpm) Speed of turntable	0-10
转盘直径 (mm) Dia. of turntable	Φ1500 (可选 Φ1650/1800/2000/2200) (optional Φ1650/1800/2000/2200)
压板直径 (mm) Dia. of top-presser	Φ450 (可选 Φ600/800) (Optional Φ600/800)
立柱高度 (mm) Mast height	2400 (可选 2000/2700/3000/3200/3400) (Optional 2000/2700/3000/3200/3400)
承重 (kg) Capacity	2000
有效高度 (mm) Effective height	立柱高度减400 Mast height minus 400
包装材料 (mm) Packaging material	宽≤500, 外直径≤Φ280 LLDPE 拉伸薄膜 W≤500, outer dia.≤Φ280 LLDPE film
压顶行程 (mm) Working height	500 - 立柱高度减400 500 - Mast height minus 400



### MH-FG-2000D 转盘在线式拉伸薄膜缠绕机 Automatic pallet stretch wrapper

电源 Power	3P AC380V 50Hz
气源压力 (MPa) Air pressure	0.6-0.8
转盘速度 (rpm) Speed of turntable	0-10
转盘直径 (mm) Dia. of turntable	Φ2000
台面高度 (mm) Table height	≥450 (滚筒型) (Roller-type)
台辊直径 (mm) Roller dia.	Φ76
立柱高度 (mm) Mast height	2400 (可选 2000/2700/3000/3200/3400) (Optional 2000/2700/3000/3200/3400)
承重 (kg) Capacity	2000
有效高度 (mm) Effective height	立柱高度减400 Mast height minus 400
包装材料 (mm) Packaging material	宽≤500, 外直径≤Φ280 LLDPE 拉伸薄膜 W≤500, outer dia.≤Φ280 LLDPE film



### MH-FG-2000P 带称重转盘式拉伸薄膜缠绕机 Pallet stretch wrapper (Weighing function)

电源 Power	1P AC220V 50Hz
转盘速度 (rpm) Speed of turntable	0-10
转盘直径 (mm) Dia. of turntable	Φ1500 (可选 Φ1650/Φ1800) (Optional Φ1650/Φ1800)
立柱高度 (mm) Mast height	2400 (可选 2000/2700/3000/3200/3400) (Optional 2000/2700/3000/3200/3400)
包装材料 (mm) Packaging material	宽≤500, 外直径≤Φ280, LLDPE 拉伸薄膜 W≤500, outer dia.≤Φ280 LLDPE film
承重 (kg) Capacity	2000
有效高度 (mm) Effective height	立柱高度减400 Mast height minus 400
称重精度 (g) Weighing accuracy	100



### MH-FG-2000D+MH-FG-2000RC 龙门旋臂式覆膜拉伸薄膜缠绕机 Pallet stretch wrapper

电源 Power	3P AC380V 50Hz
气源压力 (MPa) Air pressure	0.6-0.8
产品规格 (mm) Product specification	≤1200*1200
有效高度 (mm) Effective height	2400 (可选 2000/2700/3000/3200/3400) (Optional 2000/2700/3000/3200/3400)
覆膜材料 (mm) Film	宽≤1800, 外直径≤Φ300 PE膜 W≤1800, outer dia.≤Φ300, PE film
噪声 Noise	≤75dB (A)
环境 Environment	湿度≤90%, 温度 -10 - 40°C Humidity≤90%, temp -10 - 40°C
可选项 Optional	输送线 Conveyor line



MH-FG-2300A 龙门旋臂式拉伸薄膜缠绕机  
Pallet stretch wrapper

电源 Power	3P AC380V 50Hz
气源压力 (MPa) Air pressure	0.6-0.8
旋转速度 (rpm) Rotating speed	0-22
旋转内径 (mm) Rotating inner diameter	Φ1700
立柱高度 (mm) Mast height	2400 (可选 2000/2700/3000/3200/3400) (Optional 2000/2700/3000/3200/3400)
有效高度 (mm) Effective height	立柱高度减400 Mast height minus 400
包装材料 (mm) Packaging material	宽≤500, 外直径≤Φ280, LLDPE 拉伸薄膜 W≤500, outer dia.≤Φ280 LLDPE film



MH-FG-700A 带液车悬臂式拉伸薄膜缠绕机  
Arm rotation forklift wrapper

充电电源 Power Voltage	1P AC220V/110V 50/60Hz
转盘速度 (rpm) Speed of rotary	0-10
旋转内径 (mm) Rotating inner diameter	Φ1700
叉脚宽度 (mm) Forks width	540
压车承重 (kg) Capacity	2000
包装材料 (mm) Packaging material	宽≤500, 外直径≤Φ200 LLDPE 拉伸薄膜 W≤500, outer dia.≤Φ200, LLDPE film
机器尺寸 (mm) Machine dimension	1750*1090*2100
噪声 Noise	≤75dB (A)
环境 Environment	湿度≤90%, 温度 -10 - 40°C Humidity ≤ 90%, temperature -10 - 40°C



MH-FG-2300B 单立柱旋臂式拉伸薄膜缠绕机  
Pallet stretch wrapper

电源 Power	3P AC380V 50Hz
旋转速度 (rpm) Rotating speed	0-15
旋转内径 (mm) Rotating inner diameter	Φ2000
立柱高度 (mm) Mast height	3650
包装材料 (mm) Packaging material	宽≤500, 外直径≤Φ280, LLDPE 拉伸薄膜 W≤500, outer dia.≤Φ280 LLDPE film
机器尺寸 (mm) Machine dimension	4000*2000*3100
噪声 Noise	≤75dB (A)
环境 Environment	湿度≤90%, 温度 -10 - 40°C Humidity≤90%, temp -10 - 40°C



MH-FG-800B 带压顶式小型拉伸薄膜缠绕机  
Pallet stretch wrapper (Top presser)

电源 Power	1P AC220V 50Hz
气源压力 (MPa) Air pressure	0.6-0.8
转盘速度 (rpm) Speed of turntable	0-20
转盘直径 (mm) Dia. of turntable	Φ400, Φ600
气缸行程 (mm) Air cylinder	500
承重 (kg) Capacity	60
包装材料 (mm) Packaging material	宽≤500, 外直径≤Φ280 LLDPE 拉伸薄膜 W≤500, outer dia.≤Φ280 LLDPE film
噪声 Noise	≤75dB (A)
环境 Environment	湿度≤90%, 温度 -10 - 40°C Humidity≤90%, temperature -10 - 40°C



MH-FG-2400 旋臂固定式缠绕机  
Arm rotation fixed wrapper

电源 Power	3P AC220V 50Hz
气源压力 (MPa) Air pressure	0.6-0.8
旋转速度 (rpm) Rotating speed	0-12
旋转内径 (mm) Rotating inner diameter	Φ1700
立柱高度 (mm) Mast height	2200
包装材料 (mm) Packaging material	宽≤500, 外直径≤Φ280, LLDPE 拉伸薄膜 W≤500, outer dia.≤Φ280 LLDPE film
机器尺寸 (mm) Machine dimension	2080*1640*2850
环境 Environment	湿度≤90%, 温度 -10 - 40°C Humidity≤90%, Temp -10 - 40°C



MH-FG-900B 带夹包杆式小型拉伸薄膜缠绕机  
Power pre-stretch automatic case stretch wrapper

电源 Power	1P AC220V 50Hz
转盘速度 (rpm) Speed of turntable	0-20
有效宽度 (mm) Effective width	400
有效高度 (mm) Effective height	850
有效规格 (mm) Valid package size	L(250-1200)*W(20-400)*H(200-850)
承重 (kg) Capacity	60
包装材料 (mm) Packaging material	宽≤500, 外直径≤Φ200 LLDPE 拉伸薄膜 W≤500, outer dia.≤Φ200 LLDPE film
机器尺寸 (mm) Machine dimension	1600*600*1740



### MH-CTP-600 自走式缠绕机 Pallet wrapper

充电电源 Power voltage	1P AC220V/110V 50/60Hz
运行电源 Operating power	DC 24V
电池容量 (Ah) Battery capacity	80Ah
充电时间 Charge time	7h/一次充电 200栈板/一次充电 Charge 7 hours can wrap 200 pallets
行走速度 (m/min) Around speed	90 (可调节) (Adjustable)
栈板 (mm) Pallet size	600*(600-∞)
有效高度 (mm) Max wrapping height	2400 (可选 2800) (Option 2800)
包装材料 (mm) Film material	LLDPE拉伸薄膜, 宽≤500, 外径≤Φ250 LLDPE film, W≤500, out diameter≤250

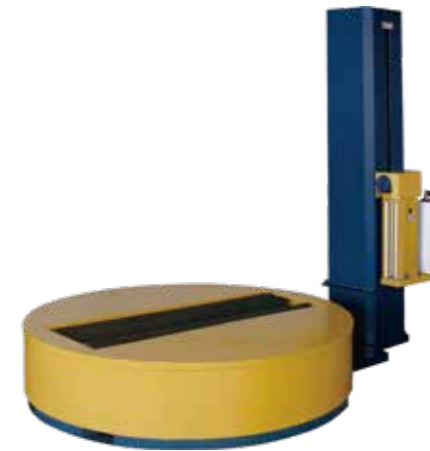

### MH-FG-2100 转盘式圆柱体专用拉伸薄膜缠绕机 Pallet stretch wrapper

电源 Power	1P AC220V 50Hz
转盘速度 (rpm) Speed of turntable	0-10
转盘直径 (mm) Dia. of turntable	Φ2000
转盘高度 (mm) Mast height	450
立柱高度 (mm) Mast height	2000
包装材料 (mm) Packaging material	宽≤500, 外径≤Φ280, LLDPE 拉伸薄膜 W≤500, outer dia.≤Φ280 LLDPE film
承重 (kg) Capacity	1500

### MH-CTR-060 水平式缠绕机 Horizontal orbital wrapper

电源 Power	1P AC220V 50Hz
气源压力 (MPa) Air pressure	0.6-0.8
旋转速度 (rpm) Rotating speed	5-100
薄膜宽度 (mm) Film width	76(3" ), 102(4" ), 127(5" )
台面高度 (mm) Table height	750 (可调节) (Adjustable)
包圆能力 (mm) Packaging ability (Round package)	Φ102-330
包方能力 (mm) Packaging ability (Rectangular package)	宽102-550, 最小高度50, 最大对角560 W 102-550, Min. height 50, Max. diagonal 560
机器尺寸 (mm) Machine dimension	1249*1315*1593
机器重量 (kg) Machine weight	315

### MH-FG-2200 卧式无纺布专用拉伸薄膜缠绕机 Horizontal pallet stretch wrapper for fabric

电源 Power	1P AC220V 50Hz
气源压力 (MPa) Air pressure	0.6-0.8
滚筒速度 (m/min) Speed of roller	24
滚筒高度 (mm) Height of roller	500
滚筒直径 (mm) Diameter of roller	Φ160
承重 (kg) Capacity	1500
适用产品 (mm) Applicable products	Dia.Φ500-1200, length 400-2200
包装材料 (mm) Packaging material	宽≤500, 外径≤Φ280 LLDPE 拉伸薄膜 W≤500, outer dia.≤Φ280 LLDPE film
机器尺寸 (mm) Machine dimension	3100*1450*1300

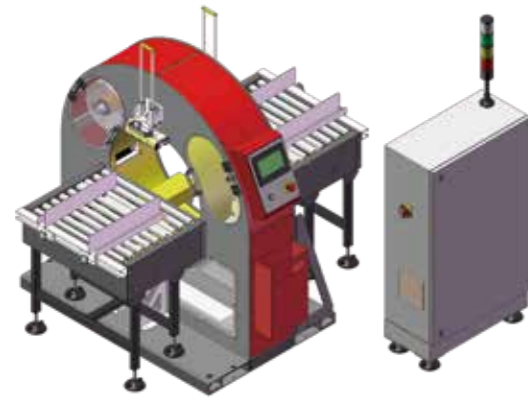

### MH-CTR-200BD 水平式缠绕机 Horizontal orbital wrapper

旋转速度 (rpm) Speed	5-30
传递方式 Transfer method	摩擦轮 Friction wheel
薄膜宽度 (mm) Film width	250 (10" )
预拉伸百分比 Pre-stretch percent	250% (可调) (Adjustable)
台面高度 (mm) Table height	850 (可调) (Adjustable)
包圆能力 (mm) Packaging ability (Round package)	Φ900-1750
包方能力 (mm) Packaging ability (Rectangular package)	宽750-1750, 最大对角1950 W 750-1750, Max. diagonal 1950
机器尺寸 (mm) Machine dimension	1630*2725*2725
机器重量 (kg) Machine weight	1260



### 可选膜架 Optional stretch carriage



- ① AS盘式阻拉膜架  
SIAT plate anti-stretch carriage
- ② A带式阻拉膜架  
Belt anti-stretch carriage
- ③ AX侧摩擦片阻拉膜架  
Side friction sheet anti-stretch carriage
- ④ AE磁粉阻拉膜架  
Magnetic anti-stretch carriage
- ⑤ B普通预拉膜架  
Normal pre-stretch carriage
- ⑥ BX两段式预拉膜架  
Two-sections pre-stretch carriage
- ⑦ BL双电机膜架  
Double motor carriage

# ROBOT & DELTA ROBOT 机器人和蜘蛛手



YSR-2-20-C 两轴机器人  
Robot

额定负载 (kg) Rated payload	20
工作范围 (mm*mm) Working area	400*800
安装方式 Mounting position	吊装式 Ceiling
自重 (kg) Weight of robot	190
重复定位精度 (mm) Pose repeatability	±0.5
轴运动 Axis data	A2 +20° to -105° A3 +55° to -95°
最大速度 Max speed	A2 160°/s A3 160°/s

YSR-2-180-F 两轴机器人  
Robot



额定负载 (kg) Rated payload	180
工作范围 (mm*mm) Working area	1000*1470
安装方式 Mounting position	落地式 Floor
自重 (kg) Weight of robot	650
重复定位精度 (mm) Pose repeatability	±0.5
占地面积 (mm) Floor area	380*450
轴运动 Axis data	A2 +40° to -85° A3 +15° to -115°
最大速度 Max speed	A2 90°/s A3 90°/s



### YSR-2-220-F 两轴机器人 Robot

额定负载 (kg) Rated payload	220
工作范围 (mm*mm) Working area	1200*1600
安装方式 Mounting position	落地式 Floor
自重 (kg) Weight of robot	950
重复定位精度 (mm) Pose repeatability	±0.5
占地面积 (mm) Floor area	430*510
轴运动 Axis data	A2 +40° to -85° A3 +15° to -115°
最大速度 Max speed	A2 80°/s A3 80°/s



### YSR-2-520-F 两轴机器人 Robot

额定负载 (kg) Rated payload	520
工作范围 (mm*mm) Working area	1200*1600
安装方式 Mounting position	落地式 Floor
自重 (kg) Weight of robot	1100
重复定位精度 (mm) Pose repeatability	±0.5
占地面积 (mm) Floor area	430*510
轴运动 Axis data	A2 +40° to -85° A3 +15° to -115°
最大速度 Max speed	A2 60°/s A3 60°/s



型号 Model	YSR-4-40-F/1900	YSR-4-120-F/3150	YSR-4-220-F/3150	YSR-4-500-F/3150
额定负载 (kg) Rated payload	40	120	220	500
最大工作半径 Reach (mm)	1900	3150	3150	3150
安装方式 Mounting position	落地式 Floor	落地式 Floor	落地式 Floor	落地式 Floor
自重 (kg) Weight of robot	420	1400	1600	2210
重复定位精度 (mm) Pose repeatability	±0.5	±0.5	±0.5	±0.5
占地面积 (mm) Floor area	440*440	900*900	900*900	950*950
轴运动 Axis data	A1: ±170° A2: +40° to -90° A3: +15° to -115° A4: ±360°	A1: ±180° A2: +40° to -90° A3: +15° to -115° A4: ±360°	A1: ±180° A2: +40° to -90° A3: +15° to -115° A4: ±360°	A1: ±180° A2: +40° to -90° A3: +15° to -115° A4: ±360°
最大速度 Max speed	A1: 120°/s A2: 135°/s A3: 135°/s A4: 300°/s	A1: 120°/s A2: 125°/s A3: 125°/s A4: 300°/s	A1: 95°/s A2: 95°/s A3: 95°/s A4: 240°/s	A1: 85°/s A2: 80°/s A3: 80°/s A4: 165°/s

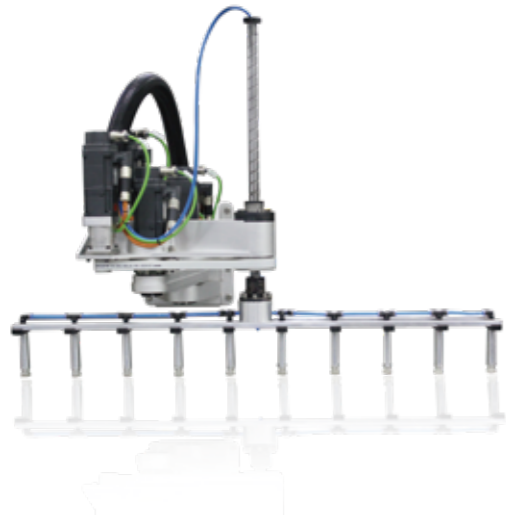

### YSRS-4-10-W 四轴机器人 Robot

额定负载 (kg) Rated payload	10
额定功率 (kW) Power supply	3
最大工作半径 (mm) Reach	600, 800
安装方式 Mounting position	侧挂式 Wall
自重 (kg) Weight of robot	50
重复定位精度 (mm) Pose repeatability	±0.5
占地面积 (mm) Floor area	230*300
轴运动 Axis data	A1: ±180°; A2: ±150° A3: 400mm; A4: ±500°
最大速度 Max speed	A1: 95°/s; A2: 95°/s A3: 95°/s; A4: 240°/s

蜘蛛机器人  
Spider robot



型号 Model	YSRD-4-01-C / YSRD-4-03-C		YSRD-3-01-C / YSRD-3-03-C			
运动学结构 Kinematic structure	Delta 类型 Delta type		Delta 类型 Delta type			
旋转轴 Rotation axis	±360°		-			
安装方式 Mounting position	吊装式 Ceiling		吊装式 Ceiling			
自重 (kg) Weight	130		125			
重复定位精度 (mm) Pose repeatability	±0.3		±0.3			
重复定位角度 Angle repeatability	±0.3°		-			
最大负载 (kg) Payload	1kg / 3kg		1kg / 3kg			
最大速度 (cycles/min) Maximum speed	160		160			
工作范围 Working volume	Φ800*250/Φ1130*300/Φ1350*350		Φ800*250/Φ1130*300/Φ1350*350			
循环时间 Cycle time	路径: 25*305*25 Cycle path	负载(kg): 0.5 Payload	循环时间(s): 0.5 Cycle time	路径: 25*305*25 Cycle path	负载(kg): 0.5 Payload	循环时间(s): 0.5 Cycle time

协作机器人  
Robot



型号 Model	YSR-6-20-F	YSR-6-25-F	YSR-6-35-F
电源 Power	输入电压220V, 工作电压48V Input 220V, operated 48V	输入电压220V, 工作电压48V Input 220V, operated 48V	输入电压220V, 工作电压48V Input 220V, operated 48V
自重 (kg) Weight of robot	60	149	147
最大负载 (kg) Maximum payload	20	25	35(40/45/50)
最大工作半径 Reach (mm)	1,600	1,900	1,650
重复定位精度 (mm) Pose repeatability	±0.1	±0.1	±0.1
最大速度 Max speed	A1: 100°/s; A2: 100°/s; A3: 120°/s; A4: 180°/s; A5: 180°/s; A6: 180°/s;	A1: 120°/s; A2: 120°/s; A3: 180°/s; A4: 180°/s; A5: 180°/s; A6: 180°/s;	A1: 120°/s; A2: 120°/s; A3: 120°/s; A4: 180°/s; A5: 180°/s; A6: 180°/s;
运行环境温度 operation temp.	-20 ~ 45°C	-20 ~ 45°C	-20 ~ 45°C
码垛高度 (mm) Palletizer height	2,100	2,100	2,100

# PALLETIZER & DEPALLETIZER MACHINE

## 码卸垛机

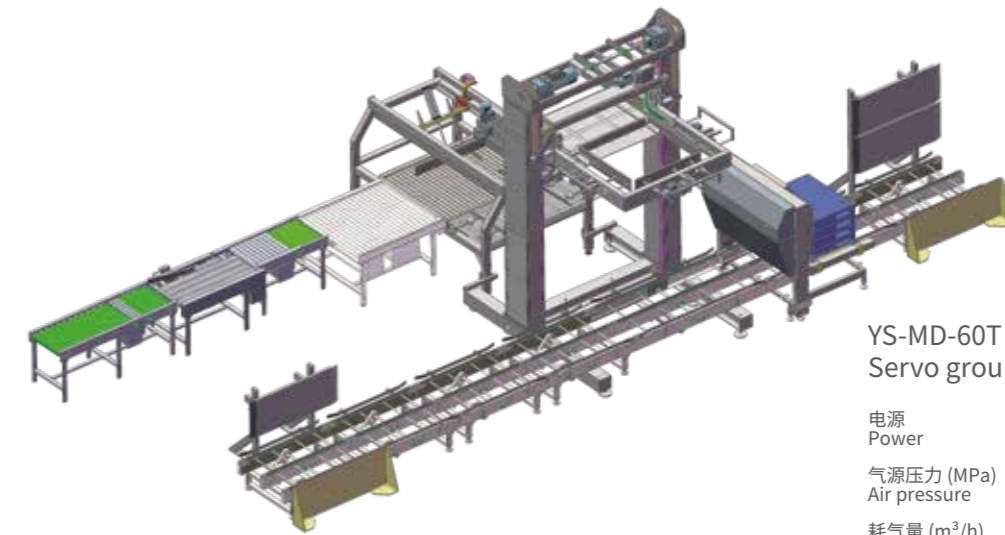

YS-MD-60T 双立柱  
Servo grouping

电源 Power	380V 50Hz 25kW
气源压力 (MPa) Air pressure	0.6-0.8
耗气量 (m <sup>3</sup> /h) Air consumption	6
生产速度 (BPH) Speed	36000
设备效率 Efficiency	≥95%
瓶子破损率 Bottle breakage rate	≤0.1‰

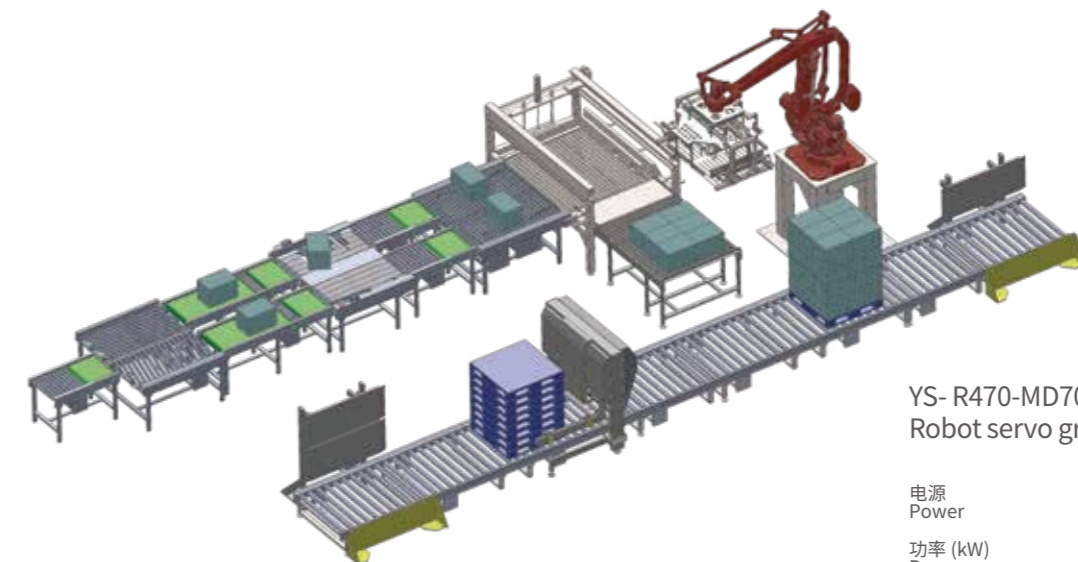
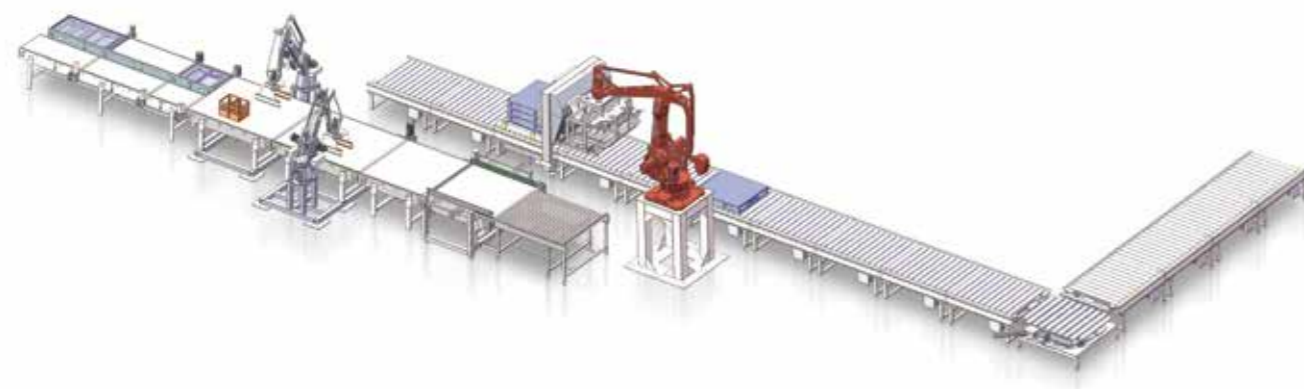

YS-R470-MD70-I 机器人伺服编组  
Robot servo grouping

电源 Power	3P AC380V 50Hz
功率 (kW) Power	16.5+26.9 (永创机器人) (YOUNGSUN robot)
气源压力 (MPa) Air pressure	0.6-0.8
生产速度 (layers/min) Speed	4.5
耗气量 (L/min) Air consumption	400
适用范围 Application	纸箱、膜包、塑箱, 可带加隔板功能 Cartons, film packages, plastic boxes, division plate is optional

YS- R470-MD80T 机器人伺服编组  
Robot servo grouping

电源 Power supply	3P AC380V 50Hz
功率 (kW) Power	20+44.3(永创机器人) (YOUNGSUN robot)
气源压力 (MPa) Air pressure	0.6-0.8
生产速度 (layers/min) Speed	6
耗气量 (L/min) Air consumption	550
适用范围 Application	纸箱、膜包、塑箱 Cartons, film packages, plastic boxes

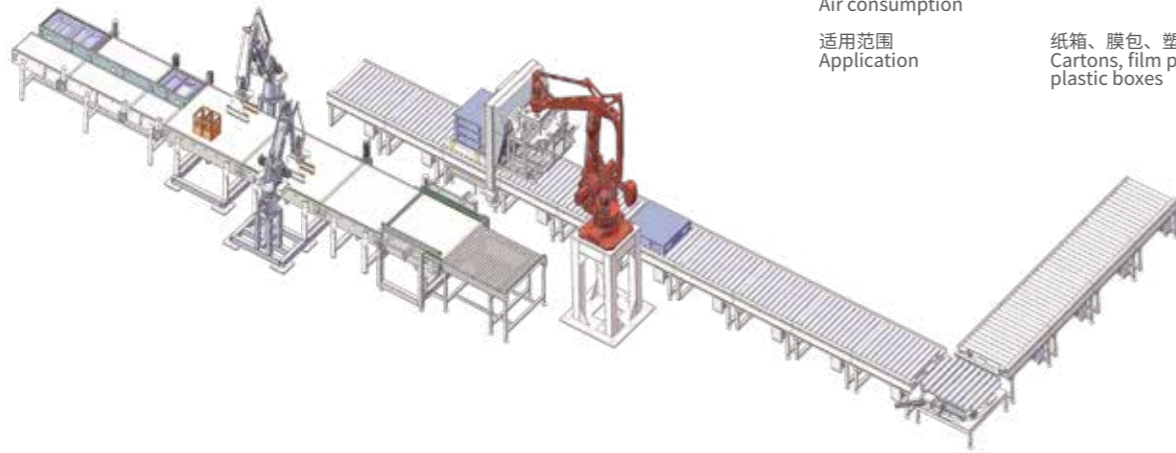

YS-R470-MD70- II 机器人伺服编组  
Robot servo grouping

电源 Power	3P AC380V 50Hz
功率 (kW) Power	16.5+26.9 (永创机器人) (YOUNGSUN robot)
气源压力 (MPa) Air pressure	0.6-0.8
生产速度 (layers/min) Speed	4.5
耗气量 (L/min) Air consumption	400
适用范围 Application	纸箱、膜包、塑箱 Cartons, film packages, plastic boxes

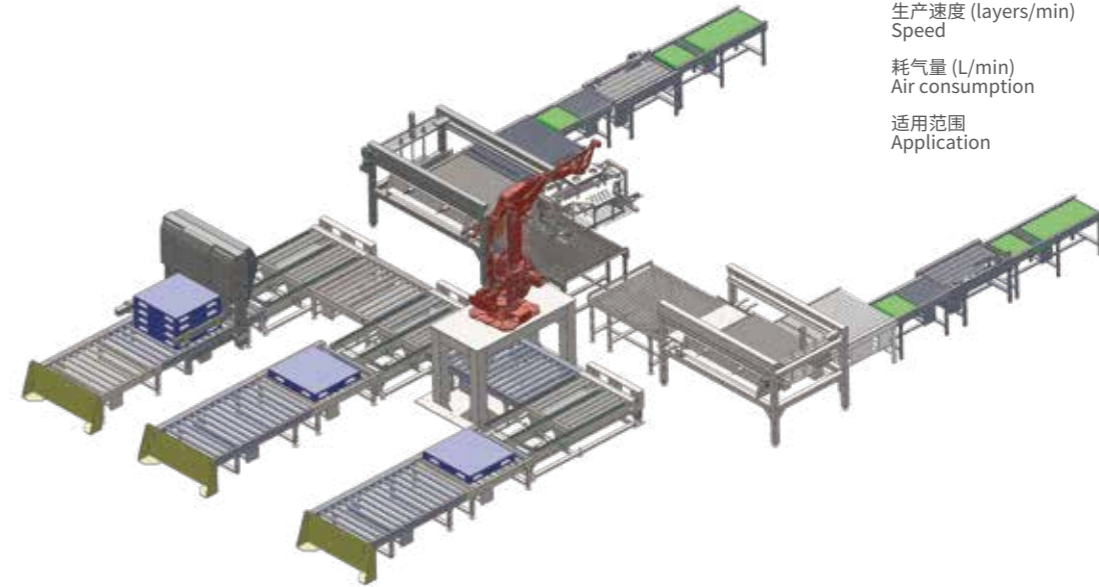

YS-R470-MD80 机器人伺服编组  
Robot servo grouping

电源 Power supply	3P AC380V 50Hz
功率 (kW) Power	27+26.9 (永创机器人) (YOUNGSUN robot)
气源压力 (MPa) Air pressure	0.6-0.8
生产速度 (layers/min) Speed	5
耗气量 (L/min) Air consumption	500
适用范围 Application	纸箱、膜包、塑箱 Cartons, film packages, plastic boxes

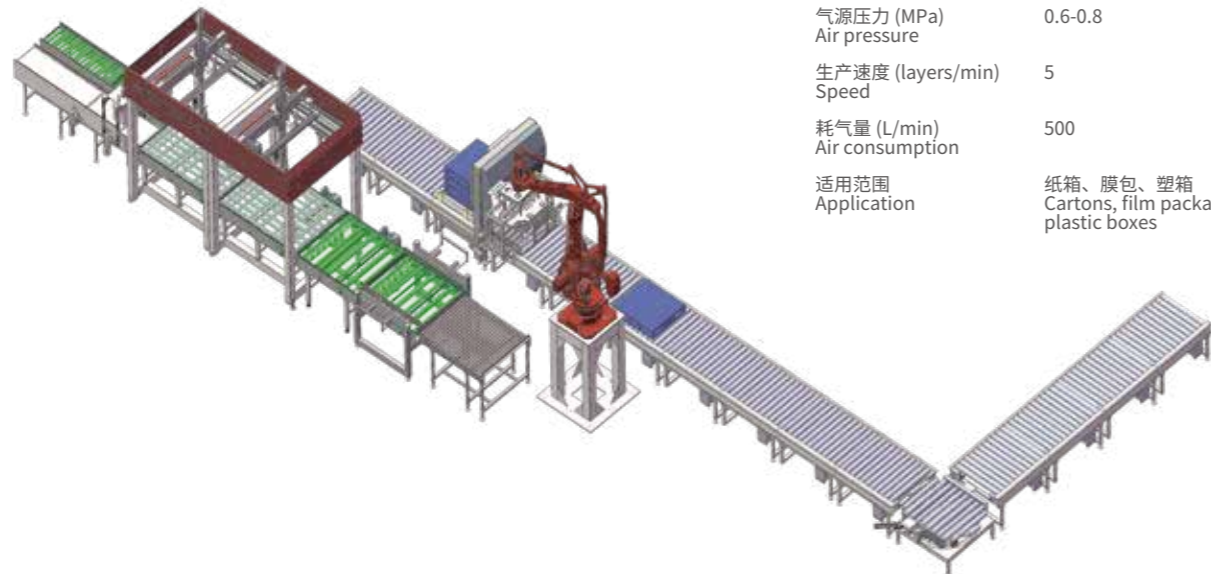

YS-R470-MD45 机器人伺服编组  
Robot servo grouping

电源 Power	3P AC380V 50Hz
功率 (kW) Power	16.5+26.9 (永创机器人) (YOUNGSUN robot)
气源压力 (MPa) Air pressure	0.6-0.8
生产速度 (layers/min) Speed	3
耗气量 (L/min) Air consumption	400
适用范围 Application	纸箱、膜包、塑箱 Cartons, film packages, plastic boxes

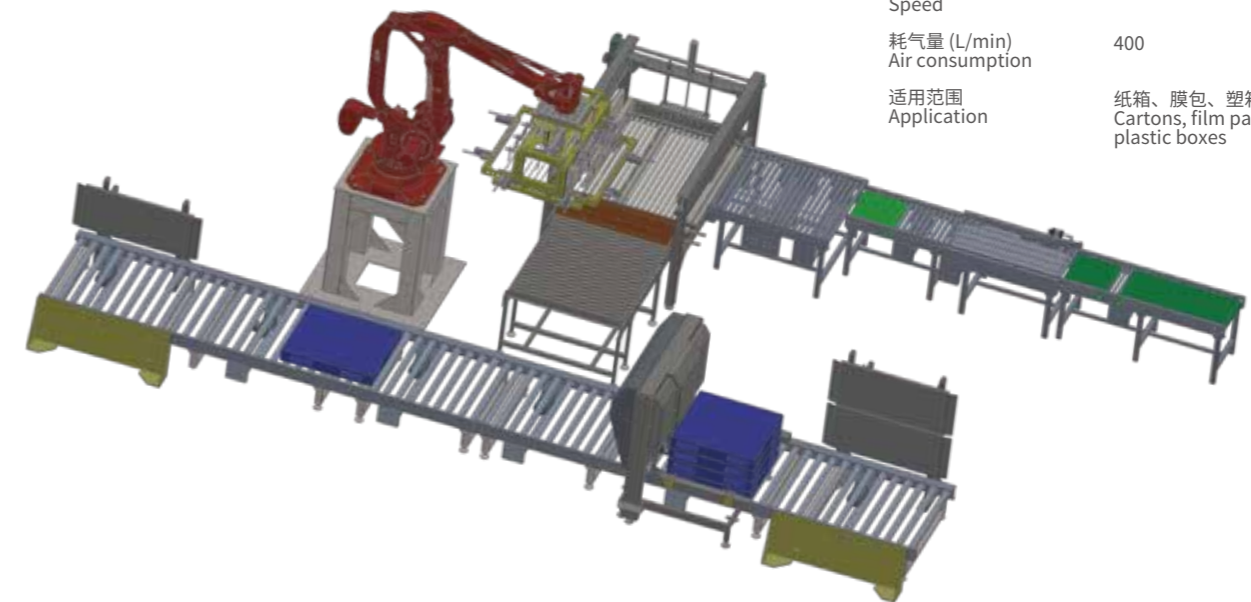

YS- R180-MD- I 机器人伺服编组  
Robot servo grouping

电源 Power	3P AC380V 50Hz
功率 (kW) Power	1.2+11 (永创机器人) (YOUNGSUN robot)
气源压力 (MPa) Air pressure	0.6-0.8
生产速度 (times/min) Speed	6-8
耗气量 (L/min) Air consumption	100
适用范围 Application	纸箱, 抓手按产品定制 Cartons, Grasp customization according to product

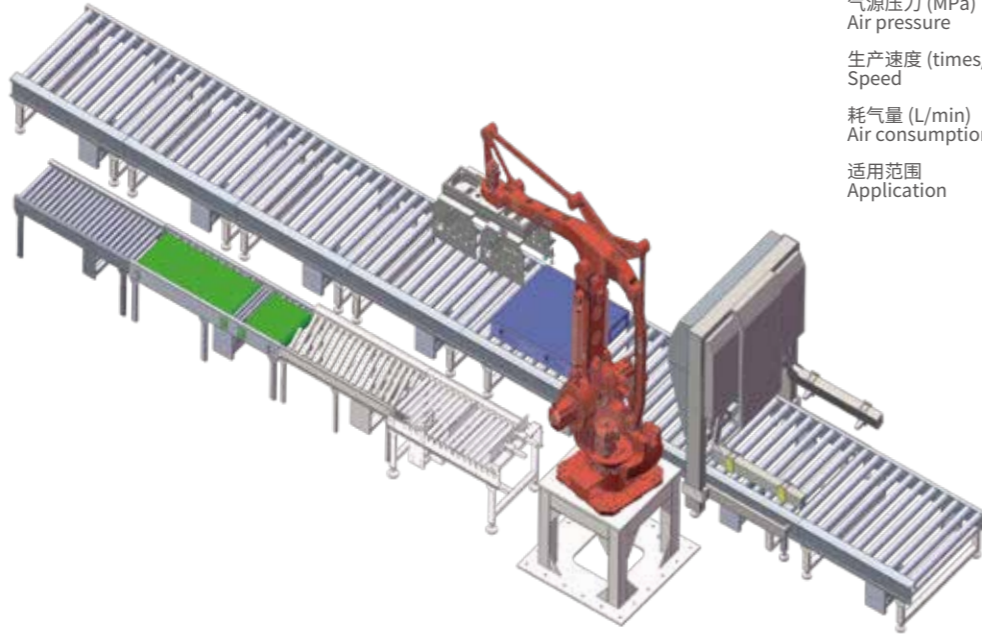

YS-XPG-50 高位卸瓶垛机  
High-position bottle depalletizer

电源及功率 Power supply	380V±5% 50Hz 28.85kW
气源压力 (MPa) Air pressure	0.6-0.8
耗气量 (L/min) Air consumption	500
生产速度 (BPH) Speed	50000
主机外形尺寸 (mm) Main machine dimension	2920*2620*4500
主机重量 Main machine weight	5000
出瓶口高度 (mm) Bottle outlet height	3500 (可定制) (Customized)

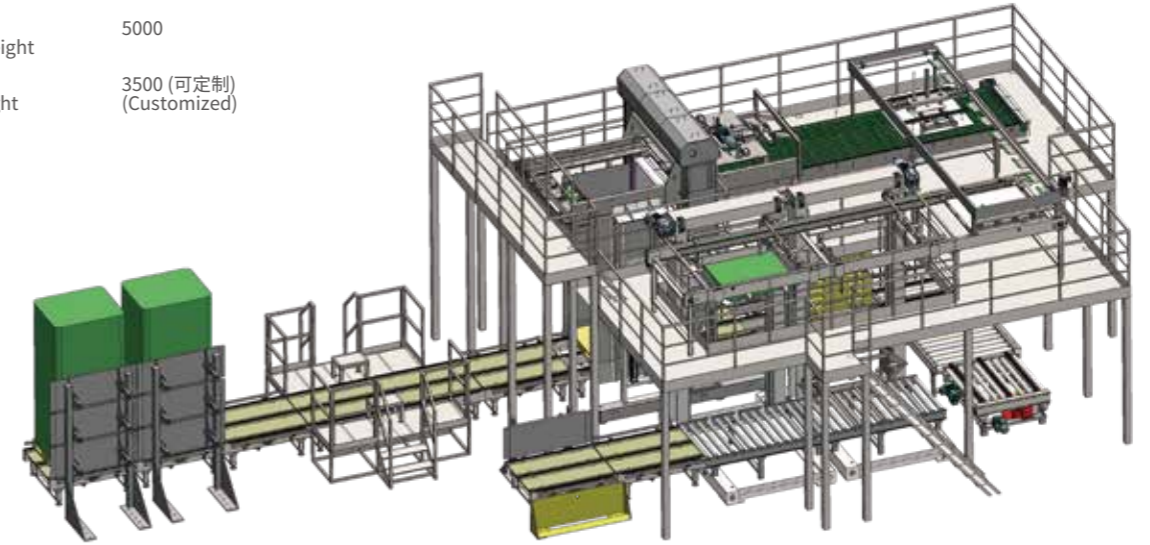

YS-XPD-36 中位卸瓶垛机  
Median bottle depalletizer

电源及功率 Power supply	380V±5% 50Hz 21.47kW
气源压力 (MPa) Air pressure	0.6-0.8
耗气量 (L/min) Air consumption	500
生产速度 (BPH) Speed	50000瓶/小时 50000 bottles/hour
主机外形尺寸 Main machine dimension	3480*2430*4980
主机重量 (kg) Main machine weight	8000
出瓶口高度 (mm) Bottle outlet height	1600 (可定制) (Customized)

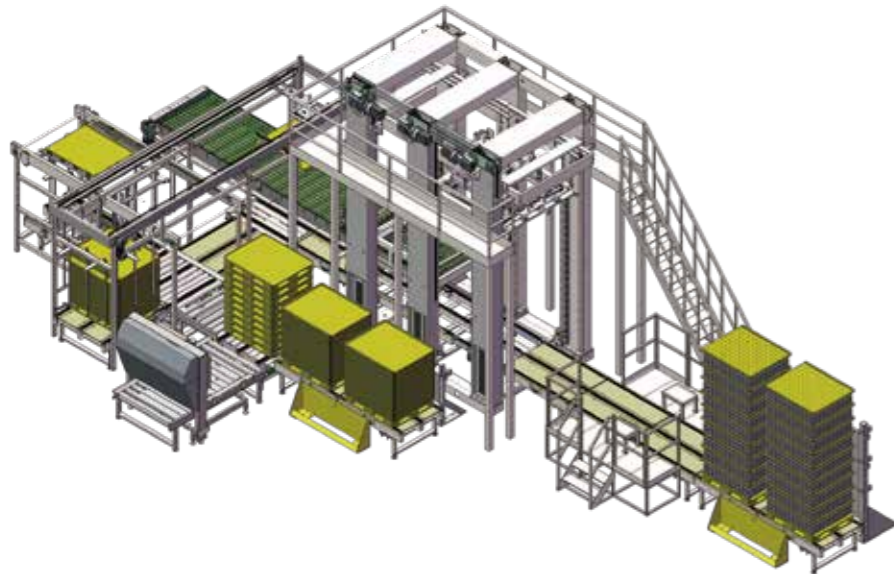

YS-XPGG-50 超高位卸瓶垛机  
Super high-position bottle depalletizer

电源 Power supply	380V±5% 50Hz 25.9kW
气源压力 (MPa) Air pressure	0.6-0.8
耗气量 (L/min) Air consumption	500
生产速度 (BPH) Speed	48000
主机外形尺寸 (mm) Main machine dimension	L4150*W2280*H5000 (H根据出瓶高度) Height according to the height of the bottle outlet
主机重量 (kg) Main machine weight	10000
出瓶口高度 Bottle outlet height	可定制 Customized

